



# THE VOLVO OPEN 70 RULE

Version:	3
Amendment:	1
Date	16/03/10

Volvo Ocean Race S.L.U. 2010 - This document may not be reproduced, transmitted or recorded by any means, in whole or in part, without the prior approval of Volvo Ocean Race S.L.U. or its successor.

## TABLE OF CONTENTS

<b>1</b>	<b>GENERAL .....</b>	<b>5</b>
1.1	FUNDAMENTAL RULE POLICY .....	5
1.2	IMPORTANT NOTICE.....	5
1.3	VOLVO OPEN 70 MEASUREMENT GROUP (MG) & INTERPRETATION GROUP (VIG).....	6
<b>2</b>	<b>RULE MANAGEMENT .....</b>	<b>7</b>
2.1	ADMINISTRATION .....	7
2.2	LANGUAGE & DEFINITIONS.....	7
2.3	INTERPRETATION .....	7
2.4	AMENDMENTS .....	8
2.5	MEMORANDA.....	8
2.6	MEASUREMENT PROTOCOL .....	8
2.7	CLASS CERTIFICATE .....	9
2.8	HULL NUMBER.....	9
2.9	DECLARATION .....	10
2.10	DOCUMENTATION .....	10
<b>3</b>	<b>DEFINITIONS.....</b>	<b>11</b>
3.1	UNITS OF MEASUREMENT .....	11
3.2	MEASUREMENT NOMENCLATURE .....	11
3.3	MAJOR AXES.....	13
3.4	FIBRE MODULUS .....	14
<b>4</b>	<b>GENERAL REQUIREMENTS .....</b>	<b>15</b>
4.1	HULL.....	15
4.2	SHEER LINE .....	15
4.3	OUTLINE .....	15
4.4	HOLLOWS .....	15
4.5	SEA COCKS & VALVES.....	15
4.6	DECK.....	15
4.7	LIFELINES, STANCHIONS & PULPITS .....	16
4.8	NAVIGATION LIGHTS .....	17
4.9	JACKSTAYS.....	17
4.10	STERN AERIAL MAST .....	18
4.11	COCKPIT .....	18
4.12	COACH ROOF .....	18
4.13	COMPANIONWAY & SPRAY DODGER .....	18
4.14	TRANSOM .....	19
4.15	PERMITTED MATERIALS FOR DECK EQUIPMENT AND DECK FITTINGS.....	19
4.16	PERMITTED MATERIALS FOR HULL, DECK (INCLUDING SPRAY DODGERS), INTERNAL STRUCTURE & INTERNAL FITTINGS .....	19
4.17	HIGH VISIBILITY MARKINGS .....	20
<b>5</b>	<b>STRUCTURAL REQUIREMENTS .....</b>	<b>21</b>
5.1	STRUCTURAL REQUIREMENTS.....	21
5.2	MINIMUM PANEL WEIGHTS .....	21
5.3	PANEL SAMPLES .....	21
5.4	WATERTIGHT SUB-DIVISION .....	22
5.5	APPENDAGE COMPARTMENTS.....	22
5.6	SUB-DIVISION OPENINGS .....	23
<b>6</b>	<b>APPENDAGES .....</b>	<b>24</b>
6.1	RUDDERS .....	24
6.2	DAGGERBOARDS.....	24
6.3	BALLAST KEEL.....	25

6.4	LOAD CASE REQUIREMENTS FOR THE KEEL, CANTING MECHANISM & ASSOCIATED STRUCTURE .....	26
6.5	PERMITTED MATERIALS FOR RUDDERS & DAGGERBOARDS .....	27
6.6	PERMITTED MATERIALS FOR BALLAST KEEL FIN (EXCLUDING CANTING MECHANISMS & SYSTEMS).....	27
6.7	PERMITTED MATERIALS FOR KEEL BULB .....	28
6.8	PERMITTED MATERIALS FOR BALLAST KEEL CANTING MECHANISMS & SYSTEMS .....	28
<b>7</b>	<b>MEASUREMENT ASHORE (SEE FIGURE 1) .....</b>	<b>29</b>
7.1	ASHORE MEASUREMENT CONDITION .....	29
7.2	DESIGN WATER LINE (DWL) .....	29
7.3	LENGTH OF HULL (LH).....	29
7.4	STATIONS.....	29
7.5	MEASUREMENT REFERENCE POINTS.....	29
7.6	FREEBOARDS .....	30
7.7	MAXIMUM BEAM (B) .....	30
7.8	DRAFT (D) .....	30
7.9	KEEL WEIGHT (KW).....	30
<b>8</b>	<b>MEASUREMENT AFLOAT .....</b>	<b>32</b>
8.1	MEASUREMENT AFLOAT .....	32
8.2	SPECIFIC GRAVITY (SG).....	32
8.3	SINK.....	32
8.4	WEIGHING .....	33
8.5	WEIGHT OF BOAT (W) .....	33
8.6	FLOATATION .....	33
8.7	CANTING KEEL ANGLE .....	33
8.8	PULL DOWN TEST.....	33
<b>9</b>	<b>STABILITY .....</b>	<b>36</b>
9.1	DAMAGED STABILITY .....	36
9.2	ANGLE OF VANISHING STABILITY (AVS) .....	36
<b>10</b>	<b>RIG MEASUREMENT (SEE FIGURE 2) .....</b>	<b>37</b>
10.1	RIG LIMITATIONS .....	37
10.2	MAST WEIGHT (MWT) & CENTRE OF GRAVITY (MCG) .....	38
10.3	MAST DATUM (MD) .....	38
10.4	MAINSAIL HOIST (P) .....	38
10.5	MAST POSITION (MP) .....	39
10.6	BASE OF FORETRIANGLE (J) .....	39
10.7	HEIGHT OF FORETRIANGLE (IG).....	39
10.8	MASTHEAD SPINNAKER HOIST (ISP) .....	39
10.9	FRACTIONAL SPINNAKER HOIST (IFR) .....	39
10.10	CHAIN PLATE WIDTH (CPW).....	39
10.11	BOOM MEASUREMENT.....	39
10.12	MAINSAIL FOOT LENGTH (E).....	39
10.13	BOOM ABOVE DATUM (BAD) .....	40
10.14	BOWSPRIT LENGTH (BSL) .....	40
10.15	PERMITTED MATERIALS FOR MAST, SPREADERS, JUMPER STRUT(S), BOOM, BOWSPRIT & ASSOCIATED STANDING & RUNNING RIGGING FITTINGS. ....	41
10.16	PERMITTED MATERIALS FOR RIGGING & ASSOCIATED FITTINGS .....	41
<b>11</b>	<b>SAIL MEASUREMENT (SEE FIGURE 3) .....</b>	<b>42</b>
11.2	MAINSAIL .....	42
11.3	SPINNAKER.....	42
11.4	HEADSAIL.....	43
11.5	STAYSAILS (SS) .....	43
11.6	HEAVY WEATHER JIB (HWJ) .....	44

---

11.7	STORM JIB .....	44
11.8	STORM TRYSAIL.....	44
11.9	SAIL & DECK BAGS .....	45
11.10	SAIL SETTING RESTRICTIONS .....	47
11.11	PERMITTED MATERIALS FOR SAILS .....	47
<b>12</b>	<b>ACCOMMODATION .....</b>	<b>48</b>
12.1	PRACTICAL REQUIREMENT .....	48
12.2	BERTHS .....	48
12.3	EQUIPMENT STATIONS.....	48
12.4	GALLEY.....	49
12.5	TOILET.....	49
12.6	EMERGENCY EQUIPMENT LOCKERS .....	49
12.7	INTERIOR COLOUR.....	50
<b>13</b>	<b>TANKS &amp; WATER MAKERS .....</b>	<b>51</b>
13.1	LOCATION .....	51
13.2	FRESHWATER TANKS & WATER MAKERS.....	51
13.3	FUEL TANKS.....	51
13.4	AFT BALLAST TANK .....	51
<b>14</b>	<b>ENGINES, PROPELLER &amp; EQUIPMENT.....</b>	<b>53</b>
14.1	MAIN ENGINE INSTALLATION .....	53
14.2	AUXILIARY ENGINE INSTALLATION .....	54
14.3	ENGINE WEIGHT DISTANCE (EWD) .....	54
14.4	MACHINERY INSTALLATION GENERAL CONDITIONS.....	54
14.5	ALTERNATORS.....	55
14.6	BATTERIES, FUSES & SWITCHES .....	55
14.7	BILGE PUMPS .....	55
14.8	RENEWABLE ENERGY SOURCE .....	56
<b>15</b>	<b>EMERGENCY STEERING SYSTEM .....</b>	<b>57</b>
15.1	EMERGENCY STEERING SYSTEM .....	57
15.2	PERMITTED MATERIALS FOR EMERGENCY STEERING SYSTEMS .....	57
	<b>APPENDIX A.....</b>	<b>58</b>
	<b>APPENDIX B.....</b>	<b>60</b>
	<b>APPENDIX C.....</b>	<b>66</b>
	<b>APPENDIX D.....</b>	<b>68</b>

## 1 **General**

### 1.1 **Fundamental Rule Policy**

The Volvo Open 70 Rule is intended to produce fast, single mast monohull keelboats, suitable for long distance racing offshore at the highest level of the sport. The need for safety and self-sufficiency is paramount. The Rule is intended to foster gradual design development leading to easily driven, seaworthy Boats of high stability, requiring moderate crew numbers. Any development that is contrary to this may give rise to a Rule change.

### 1.2 **Important Notice**

**OCEAN GOING BOAT RACING IS A HAZARDOUS ACTIVITY. ANYONE INTENDING TO PARTICIPATE IN OR BECOME INVOLVED IN THE RACING OF A VOLVO OPEN 70, EITHER AS A PARTICIPANT OR OTHERWISE, DOES SO AT THEIR OWN RISK AND SUCH INDIVIDUALS SHOULD RECOGNISE THAT THEY MAY SUFFER INJURY AND/OR LOSS OR DAMAGE AS A RESULT OF SUCH INVOLVEMENT. THE ADMINISTRATIVE AUTHORITY TAKES NO RESPONSIBILITY. PARTICIPANTS OR OTHERS VOLUNTARILY BECOMING INVOLVED RECOGNISE THAT SUCH EXCLUSIONS AND INDEMNITIES ON THE PART OF AND FOR THE ADMINISTRATIVE AUTHORITY AND OTHERS INVOLVED IN THE MANAGEMENT AND ORGANISATION OF THE VOLVO OPEN 70 CLASS ARE APPROPRIATE AND REASONABLE IN THE CIRCUMSTANCES AND RECOGNISE THEIR OWN OBLIGATION TO SECURE APPROPRIATE INSURANCE AND TO BRING THIS NOTICE AND THESE EXCLUSIONS AND INDEMNITIES TO THE NOTICE OF ANY THIRD PARTY WHOM THEY INVOLVE OR SEEK TO INVOLVE IN ANY WAY IN THE VOLVO OPEN 70 CLASS.**

### 1.3 Volvo Open 70 Measurement Group (MG) & Interpretation Group (VIG)

#### 1.3.1 Appointment

Volvo Event Management UK Ltd (VEMUK) shall appoint the VIG and its chairman. The OA shall also appoint the MG and the Chief Measurer.

#### 1.3.2 Jurisdiction

All matters relating to the measurement of the Volvo Open 70 Boats, or determination as to whether a Boat meets the Volvo Open 70 v3 Rules, or RRS Appendix G and ERS insofar as they relate to a Boat's equipment, shall be determined by the MG.

The VIG shall interpret the words used in such documents and issue either confidential or public interpretations. An interpretation may not change a rule.

#### 1.3.3 Decisions final and binding

Decisions of the VIG within its jurisdiction shall be final and shall not be referred to any court or other tribunal for review in any manner except that any matter relating to the jurisdiction of the VIG shall be solely determined by the OA appointed Arbitration Panel.

Decisions of the MG within its jurisdiction shall be final and shall not be referred to any court or other tribunal for review in any manner except that any matter relating to the jurisdiction of the MG shall be solely determined by the IJ.

#### 1.3.4 Delegation

The Chief Measurer may delegate one or more members of the MG to carry out measurement or inspection on behalf of the MG and they shall be entitled, in the absence of manifest error, to act on a report of any such delegated member of the MG.

#### 1.3.5 Interpretation Group (VIG)

<b>Chairman:</b>	Andy Cloughton	<a href="mailto:VIG@volvoceanrace.com">VIG@volvoceanrace.com</a>
	Ken McAlpine	
	Shaun Ritson	

#### 1.3.6 Chief Measurer

	Shaun Ritson	<a href="mailto:Measurers@volvoceanrace.com">Measurers@volvoceanrace.com</a>
--	--------------	--

## 2 **RULE MANAGEMENT**

### 2.1 **Administration**

- 2.1.1 The Volvo Open 70 Rule v 3 is a system of measurement and limitations to classify Boats for competition without time allowance.
- 2.1.2 The Volvo Open 70 Rule v 3 has been drafted to reflect the experience gained from those actively involved in previous Volvo Ocean Races. It is not possible to foresee every eventuality or to anticipate design innovation. Consequently, if it is found necessary to make any changes to the Volvo Open 70 Rule, to prevent unforeseen developments outside of the intent of the Fundamental Rule Policy, the VIG shall consider and may make any such amendments (see rule 2.4).
- 2.1.3 Any aspect of a Volvo Open 70 Boat that has a patent applied to it shall be permitted, provided that it is available to all competitors at reasonable commercial terms. Any disputes arising shall be strictly between the patent holder and the user. The Volvo Open 70 Rule shall not interpret nor enforce any such patent.
- 2.1.4 This Version 3 of the Volvo Open 70 Rule applies to the Volvo Ocean Race 2011-12 and supersedes the previous version and all interpretations and amendments thereof. Any reference to the Event means the Volvo Ocean Race 2011-12.

### 2.2 **Language & Definitions**

- 2.2.1 The language of the Volvo Open 70 Rule is English. The meaning of any word shall be by reference to the Oxford English Dictionary (2009) – CD Rom Version 4.0 (Oxford University Press 2009).
- 2.2.2 The words 'shall' and 'must' are mandatory. The words 'can' and 'may' are permissive. The word 'should' is advisory.
- 2.2.3 Any reference to the Equipment Rules of Sailing (ERS) is more specifically defined as the Equipment Rules of Sailing current at the start of that event. References in italics, capital letters or words beginning with a capital letter e.g. RRS, or Rule shall have the same definition as that contained in the Notice Of Race for the Volvo Ocean Race 2011-12, NOR 1.
- 2.2.4 Any reference to full inversion shall mean the capsize of the Boat to 180 degrees from the measurement condition about the longitudinal water plane.

### 2.3 **Interpretation**

- 2.3.1 Interpretations of the Volvo Open 70 Rule shall only be made by the VIG. Each member of the VIG shall have an equal vote in all interpretative issues. Only participants or their representative, the OA, RC and the MG may request interpretations. An interpretation shall not change a Rule.
- 2.3.2 All requests for Public Interpretation shall be submitted in writing to the Chairman of the VIG at [VIG@volvooceanrace.com](mailto:VIG@volvooceanrace.com) Questions will be answered in writing by sequentially numbered Public Interpretations, which shall be distributed to all Participants as soon as reasonably possible, and shall be available at <http://.NoticeBoard.VolvoOceanRace.com>. If the VIG considers that an issue requires wider consultation, it may seek outside opinion at the discretion of its Chairman. If a member of the MG is in doubt as to the application of the Rule to any characteristic of design or construction he shall seek a Public Interpretation.

- 2.3.3 All requests for Confidential Interpretations shall be submitted in writing to the VIG. Questions shall be answered in writing by sequentially numbered Confidential Interpretations, which shall be issued to the party seeking the interpretation as soon as reasonably possible, and shall be distributed to all Participants, and shall be available at <http://.NoticeBoard.VolvoOceanRace.com>, on the 1st April 2011. Confidential Interpretations shall not be sought or issued after the 31st March 2011. If the VIG considers that an issue requires wider confidential consultation, it may seek outside opinion at the discretion of its Chairman.
- 2.3.4 Only formal interpretations signed by the Chairman, on behalf of the VIG, are definitive. These interpretations shall be deemed to be part of the relevant rule under the Volvo Open 70 Rule. Participants are advised that an interpretation should be sought if there is any doubt as to compliance of a development with the Fundamental Rule Policy of the Volvo Open 70 Rule. An interpretation may not change a rule.
- 2.3.5 To assist in the preparation of an interpretation, the VIG may require additional sketches or drawings to determine the likely manifestation of a proposed design feature on the completed yacht. Such drawings will remain confidential to the VIG and need not be published as part of the interpretation.

## 2.4 Amendments

With the approval of the OA the VIG may make amendments to the Volvo Open 70 Rule if necessary due to changes of mandated equipment, and/or any other aspect deemed necessary. All amendments shall be available at <http://.NoticeBoard.VolvoOceanRace.com>.

## 2.5 Memoranda

The MG may issue memoranda on measurement equipment, procedures, and related information. Such memoranda are considered to be guidance information. All memoranda shall be available at <http://.NoticeBoard.VolvoOceanRace.com>.

## 2.6 Measurement Protocol

- 2.6.1 Only measurement data determined by MG is definitive in confirming compliance with the Volvo Open 70 Rule.
- 2.6.2 Measurement equipment specification and measurement methodology are determined by the MG and will be available to all Participants or their representatives. The measurement equipment used by the MG is to be manufactured and certified (where required) to comparable levels of accuracy. Measurements required to be taken to the millimetre are to be conducted using steel tape measures certified to a recognised standard. The measurement tapes and other measurement equipment used by the MG constitute the reference devices for determining compliance with the Volvo Open 70 Rule v.3.
- 2.6.3 When possible; measurement shall be conducted by two members of the MG working together. Any required measurement may be conducted by a single member of the MG. However, measurement conducted by a single member of the MG may be subject to confirmation by two members at a later date. In all cases the MG shall exercise care to produce consistent, repeatable results at all stages of the measurement process.

- 2.6.4 Following the first measurement carried out by any member(s) of the *MG*: the replacement, alteration or repair of any component, including like-for-like replacement or repair which may affect the Measurement Certificate shall be reported to the *MG* in writing by the *Participant* or their authorised representative. The *MG* shall then determine whether such replacement, alteration or repair requires further measurement by the *MG* to ensure compliance with the Volvo Open 70 Rule v.3. When the *Participant* is uncertain as to the need to lodge a report: it is the obligation of the *Participant* to consult with and be bound by the decision of the *MG*.
- 2.6.5 After Measurement Ashore (see Rule 7) is carried out by the *MG*, the reference screws marking RPD, RPS, RPF, RPU, RPL, RPA (see Rule 7.5), or any other reference datum determined by the *MG*, shall not be removed, even if later to be reinstalled, without written approval of the Chief Measurer. Failure to comply with this rule may require the Boat to be returned to Measurement Ashore Condition (see Rule 7.1), at which time the *MG* may carry out any additional measurements necessary to verify compliance with the Volvo Open 70 Rule v.3.

## 2.7 Class Certificate

- 2.7.1 The certificate of a Boat's compliance with the Volvo Open 70 Rule v.3 may only be issued to the Participant, owners or charterers following agreement by 2 members of the *MG*.
- 2.7.2 No Boat may have more than one valid certificate at any one time.
- 2.7.3 No Boat may be issued a certificate without prior allocation of a Volvo Open 70 Hull Number (see rule 2.8).
- 2.7.4 When the *MG* determines that a Boat does not comply with the Volvo Open 70 Rule v.3., that Boat's certificate shall be withheld or made invalid. Any changes to the Boat which alter the certificate values shall invalidate that certificate with the exception of weight (W), which must remain within the rule limits (see Rule 8.5). It is noted that any change which affects sink by 1mm or greater in measurement afloat condition will invalidate the certificate. Specific attention is drawn to rules 7.6, 7.8 & 8.6. Exceptionally, exemptions from Rule compliance may be considered for Volvo Open 70 Boats with hull numbers of 14 and less in accordance with Rule 2.7.6.
- 2.7.5 A copy of any valid certificate will be supplied on request to any Participant.
- 2.7.6 An exemption to parts of the Volvo Open 70 Rule v.3 may be granted to Volvo Open 70 Boats with hull numbers of 14 and less. Such exemptions shall only be granted with full agreement from the OA. Any such exemptions shall only be granted where the alternative solution to full Rule compliance is deemed to demonstrate an equivalent level of safety to full Rule compliance and is consistent with the Fundamental Rule Policy. A request for each exemption shall be made using the form in Appendix D. The Chief Measurer may require additional information at his discretion. An application for exemption is not approved until the application is signed and dated by the Chief Measurer and Race Director. Exemptions that are granted will not automatically be applied to another yacht. Applications for further exemptions will be considered on a case by case basis.

## 2.8 Hull Number

- 2.8.1 A Boat shall have been allocated a Volvo Open 70 Hull Number by the Chief Measurer prior to panel sample testing by a *MG* (see rule 5.3)
- 2.8.2 Application for a Volvo Open 70 Hull Number shall be made to the Chief Measurer in writing. An application shall include a hull lines plan, and general arrangement drawing, preliminary where necessary, with a declaration from the designer that these are the

design plans provided to the builder. The designer shall inform the Chief Measurer of any subsequent changes.

- 2.8.3 Volvo Open 70 Hull Numbers shall be issued sequentially. A Boat shall retain the same number irrespective of any future modifications, alterations or change of ownership.

## **2.9 Declaration**

The declarations found in Appendix B shall be signed by the designer and manufacturer of each boat, spar, appendage, and ballast keel canting system, in the presence of a member of the OA, MG, RC or their representative, When the declaration can not be signed in the presence of one of the above, the original declaration shall be co-signed by a representative of the Participant under the same conditions and shall be submitted to the MG prior to a certificate being issued. Electronic signatures are not acceptable. Other Rules may add to this Volvo Open 70 Rule.

## **2.10 Documentation**

In addition to the required declarations, the documentation supplied to the Chief Measurer shall not be less than the following;

Hull lines plan

General arrangement drawing

Calculations demonstrating compliance with Rule 4.11.2

Calculations demonstrating compliance with Rule 5.6.11

Calculations demonstrating compliance with Rule 9.1

A full 360 degree stability curve demonstrating compliance with Rule 9.2

### 3 **DEFINITIONS**

#### 3.1 **Units of Measurement**

- 3.1.1 All measurements shall be taken and recorded in the metric system.
- 3.1.2 Except as otherwise specified, linear measurements shall be taken and recorded in millimetres.
- 3.1.3 Sail measurements shall be taken and recorded to the nearest centimetre.
- 3.1.4 Construction core samples shall be measured and recorded to the nearest 0.1 millimetres
- 3.1.5 The weight of the boat (W) and the keel (KW) shall be weighed and recorded to the nearest 10 kgs.
- 3.1.6 The weight of the fin (FW) shall be weighed and recorded to the nearest 5 kgs.
- 3.1.7 The weight of mast, spars, and appendages not specified above shall be weighed and recorded to the nearest 0.5 kgs.
- 3.1.8 Construction core samples shall weighed and recorded to the nearest 0.01 of a gram.
- 3.1.9 Any other weights, if used, shall be recorded to the nearest 0.1kg.
- 3.1.10 Angles shall be to the nearest 0.1 degree.

#### 3.2 **Measurement Nomenclature**

<b>Abbreviation</b>	<b>Description</b>	<b>Paragraph</b>
AFS	Aft Freeboard Station	7.4.3
AFM	Aft Freeboard	7.6
AVS	Angle of Vanishing Stability	9.2
B	Maximum Beam	7.7
BAD	Boom Above Datum	10.13
BSL	Bowsprit Length	10.14
CPW	Chain Plate Width	10.10
D	Draft	7.8
DWL	Design Water Line	7.2
E	Mainsail Foot Length	10.12
ERS	ISAF Equipment Rules of Sailing	2.2.3
EWD	Engine Weight Distance	14.3
FFM	Forward Freeboard	7.6

FFS	Forward Freeboard Station	7.4.1
FW	Fin Weight	6.3.3
HLP	Headsail Luff Perpendicular	11.4.6
HWJ	Heavy Weather Jib	11.6
HWJA	Heavy Weather Jib Area	11.6.6
IFR	Fractional Spinnaker Hoist	10.9
IG	Height of Foretriangle	10.7
ISAF	International Sailing Federation	2.2.3
ISP	Masthead Spinnaker Hoist	10.8
IJ	International Jury	1.3.3
J	Base of Foretriangle	10.6
KW	Keel Weight	7.9
LLA	Limit of Length Aft	7.3
LLF	Limit of Length Forward	7.3
LH	Length of Hull	7.3
MCG	Mast Centre of Gravity	10.2
MCW	Mainsail Cap Width	11.2.3
MD	Mast Datum	10.3
MFM	Mid Freeboard	7.6
MFS	Mid Freeboard Station	7.4.2
MG	Volvo Open 70 Measurement Group	1.3
MHW	Mainsail Half Width	11.2.6
MLE	Mainsail Leech Length	11.2.2
MLW	Mainsail Lower Width	11.2.7
MP	Mast Position	10.5
MSA	Mainsail Area	11.2.9
MTW	Mainsail 3/4 Width	11.2.5
MUW	Mainsail Upper Width	11.2.4
MWL	Measurement Water Line	8.6.1
MWT	Mast Weight	10.2

OA	Organising Authority	1.3
P	Mainsail Hoist	10.4
PBO	Polybenzoxazoles	10.16.1
RPA	Reference Point Aft	7.5.5
RPD	Reference Point Deck	7.5.6
RPF	Reference Point Forward	7.5.1
RPL	Reference Point Mid Lower	7.5.4
RPS	Reference Point Stem	7.5.2
RPU	Reference Point Mid Upper	7.5.3
RRS	ISAF Racing Rules of Sailing	2.2.3
SAR	Search and Rescue	4.17.1
SF	Spinnaker Foot Length	11.3.3
SG	Specific Gravity of Water	8.2
SHW	Spinnaker Half Width	11.3.4
SJA	Storm Jib Area	11.7.6
SLE	Spinnaker Leech Length	11.3.6
SLU	Spinnaker Luff Length	11.3.5
SPA	Spinnaker Area	11.3.7
SS	Staysail	11.5
SSA	Staysail Area	11.5.6
STP	Std. Atmospheric Temperature & Pressure	4.16.4
VIG	Volvo Open 70 Interpretation Group	1.3
W	Weight of the Boat	8.5

### 3.3 Major axes

The three major axes of the boat at 90<sup>0</sup> to each other - vertical, longitudinal and transverse – shall be related to DWL (see rule 7.2) in measurement trim and to the hull centreplane.

### 3.4 Fibre Modulus

Maximum permitted fibre modulus shall be determined from the batch-nominal elastic modulus of the fibres in a fibre reinforced thermoset plastic laminate, using the measurement methods listed below, with the modulus measured in the strain range between 1 and 6 microstrains:

	SACMA-SRM16	ASTM D 4018	JIS R 7601
High Strength	245GPa	245GPa	251GPa
Intermediate Modulus	300GPa	300GPa	310GPa
High Modulus	392GPa	392GPa	405GPa

## **4 GENERAL REQUIREMENTS**

### **4.1 Hull**

No point on the hull, in any transverse section below a point 200mm below the edge of the deck (see rule 4.6), shall be lower than any point nearer to the centreplane, except as specifically permitted in rule 4.4.1, 4.4.3, 4.4.4, 4.4.5 & 4.4.6. The hull shall be symmetrical about the centreplane.

### **4.2 Sheer Line**

The sheer of the boat in elevation at the edge of the deck (see rule 4.6.1) shall be a fair continuous concave curve, the minimum radius of curvature at any point between FFS (see rule 7.4.1) and AFS (see rule 7.4.3) shall not be less than 19.000m.

### **4.3 Outline**

The outline of the boat in plan view shall be a fair and continuous convex curve, the minimum radius of curvature at any point between FFS (see rule 7.4.1) and AFS (see rule 7.4.3) shall not be less than 19.000m.

### **4.4 Hollows**

There shall be no hollows in the surface of the hull in any transverse plane, measured as a great circle from points symmetrical about the centreplane, except as follows:

- 4.4.1 As caused solely by fixed fittings.
- 4.4.2 Forward of a point 7.000m aft of LLF (see rule 7.3).
- 4.4.3 At recesses at the attachment of the keel. Such recesses shall not extend outside a projected area on the hull surface of 4.750m long by 1.500m wide.
- 4.4.4 At recesses, fairings and/or cut-outs, solely for the attachment of rudders and daggerboards, including any related bearing arrangements.
- 4.4.5 As caused by through hull openings, and associated scoops, including aft ballast tank inlets and outlets.
- 4.4.6 At recesses, fairings and/or cut-outs, solely caused by the propulsion system (see rules 14.1.3, 14.1.4, 14.1.5 and 14.1.6).

### **4.5 Sea Cocks & Valves**

All through-hull openings below 200mm above DWL, except openings for integral deck scuppers, shaft log, speed indicator, depth finders and other fixed instrument sensors, shall have a means of closing.

### **4.6 Deck**

- 4.6.1 The deck is described as any surface within and above the sheerline. The edge of the deck shall be measured at a 45 degree tangent to the hull/deck joint in any transverse section.

- 4.6.2 The deck shall have positive camber in all transverse sections, excluding the cockpit and other permitted recesses (see rule 4.6.4, 4.6.5 & 4.11). In this context, positive camber means that no point on the deck, in transverse section, shall be higher than any point nearer the centreplane.
- 4.6.3 Any opening in the deck, including openings in the coach roof and cockpit, shall have a permanently attached means of closure which shall be capable of preventing the ingress of water in the event of capsize, in compliance with ISO12216:2002: Small craft - Windows, Portlights, hatches, deadlights and doors – Strength, watertightness requirements. Any hinged hatches shall have the hinges located at the forward edge of the hatch.
- 4.6.4 Recesses of appropriate size at the forestay and/or inner forestay attachment point to allow a headsail furling drum, furling lines and tack tensioning/Cunningham arrangements to be essentially below the deck are permitted. The tack point of the sail shall remain at or above the edge of the deck. The forestay shall be attached on the centreplane and the tack point of any headsail hoisted on the forestay shall be attached on the centreplane.
- 4.6.5 A recess, or recesses, of appropriate size at the mast collar, for the leading of running rigging and associated turning blocks is permitted. Recesses of appropriate size at individual fittings are also permitted.
- 4.6.6 All winches shall be mounted in such a way that the entire rotating body of the drum is above the edge of the deck.
- 4.6.7 All winches, jammers, turning blocks, and other equipment for the purpose of adjusting sails and/or rigging shall be installed so that such equipment can be utilised entirely from the deck with all hatches closed.
- 4.6.8 No device shall be employed to assist crew in positioning their bodies and/or any stowed equipment outboard of the lifelines.
- 4.6.9 A toe rail of minimum height 40mm shall be permanently fitted around the foredeck from abreast the mast to no greater than 1m aft of FFS (see rule 7.4.1), except in way of fittings, and as close as practical to the vertical axis of stanchion bases. Toe rails shall be rigid in construction and permanently fixed to the deck.

#### **4.7 Lifelines, Stanchions & Pulpits**

- 4.7.1 Pulpits and stanchions shall be 31.75mm nominal or larger outside diameter 316 stainless steel round tube with a minimum wall thickness of 2.0 mm. Any pulpit and stanchion fitting or component shall be no lighter than the equivalent fitting or component made of stainless steel and shall be of similar or greater load bearing characteristics. The outermost part of pulpit tubes and stanchion tubes at their base, shall be located between the edge of the deck and 150mm inboard. When there are sockets or studs, these shall be through-bolted and/or bonded. The pulpit(s) and/or stanchions shall be mechanically retained without the help of the lifelines, and shall not be hinged.
- 4.7.2 Lifelines and pulpit rails shall be continuous around the edge of the deck. Exceptionally, the upper rail of bow pulpits may be omitted across the centreline of the Boat for a width not exceeding 360 mm. The lower rail shall be continuous across the centreline of the Boat and shall be arranged such that there is no greater gap than 360mm from the underside of the rail or pulpit stanchion to any part of the boat. This requirement shall be checked by presenting a 360mm diameter circle inside the opening. Pad-eyes shall be fitted and the forward end of the lifelines shall be secured such that the lines remain taught in the absence of or damage to a bow pulpit. Lifelines shall be continuous across the transom at the same height as the side deck lifelines at that point.

- 4.7.3 Lifelines shall be permanently supported by pulpits and stanchions at intervals with gaps of not more than 1.700m and shall not pass outboard of supporting stanchions. Lifelines shall not be supported by standing rigging.
- 4.7.4 Pulpit and stanchion bases may extend round the sheer and down the topsides.
- 4.7.5 There shall be at least 2 lifelines. The upper lifeline shall be permanently supported a minimum of 610mm above the edge of the deck. No vertical opening shall exceed 380mm and permanent support for the intermediate lifeline shall be not less than 230mm above the edge of the deck. Where pulpit rails replace lifelines, the same vertical spacing of permanent support requirements shall apply. Exceptionally, between the aft stanchions/pulpit rails which form part of the Stern Aerial Mast (see rule 4.10), the vertical spacing from the cockpit sole to the permanent support for the lower lifeline may be up to 990mm, to allow for open access to the life rafts from the water. Other than between the stanchions/Stern Aerial Mast immediately adjacent to the life rafts, the standard spacing shall be applied.
- 4.7.6 Lifelines shall be stranded stainless steel wire of Grade 316 5mm diameter or greater. Lifelines shall be un-coated and without any covering.
- 4.7.7 A lanyard of synthetic rope may be used to secure lifelines provided the gap it closes does not exceed 100mm.
- 4.7.8 Stanchions shall not be angled at more than 10 degrees from vertical at any point. Stanchions shall be straight, except that one bend is permitted in the first 50mm above deck. This rule shall not apply to pulpits.
- 4.7.9 Pulpits shall be designed such that they provide a secure enclosure which allows the crew to work safely within the lifelines.

#### **4.8 Navigation Lights**

- 4.8.1 Navigation lights shall be mounted so that they will not be masked by sails or the heeling of the boat, and shall be no lower than immediately under the upper lifelines.
- 4.8.2 Approved LED red and green navigation lights mounted at the masthead and a single approved LED white stern light mounted at or near the transom are considered to comply with this rule. A permanently installed approved white steaming light, at least 5m above MD (see rule 10.3) for use when under power shall be fitted.

#### **4.9 Jackstays**

- 4.9.1 Jackstays shall be fitted on deck, port and starboard of the centre line of the boat to provide secure attachments for safety harnesses. Jackstays shall be comprised of flat webbing of 20kN breaking strength, and/or braided cord of minimum diameter 10mm and 40kN breaking strength. Minimum breaking strengths given above shall apply to the full length of any material, including stitched and spliced terminations.
- 4.9.2 Jackstays shall be attached to suitable and strong anchorage points. Jackstays shall be fitted in such a way that a crew member wearing a harness, when clipped on, can move around the main deck and cockpit with minimal need for unclipping from the jackstays.
- 4.9.3 A crew member wearing a harness shall be able to clip on before coming on deck, unclip after going below and remain clipped on while moving across the boat on the foredeck, in the cockpit, and amidships. If necessary, additional jackstays and/or suitable anchorage points shall be provided for this purpose.

- 4.9.4 Suitable and strong anchorage for safety harnesses shall be provided adjacent to stations such as sheet winches and the mast, where crew members work for long periods. Specifically, anchorage points shall be provided at each steering pedestal. Jackstays should be sited in such a way that the safety harness lanyard can be kept as short as possible.

#### **4.10 Stern Aerial Mast**

- 4.10.1 This rule may be amended by the Notice of Race.
- 4.10.2 The Organising Authority shall provide a drawing of the stern aerial mast by March 1 2010. This drawing shall show the layout of communication equipment and space on the mast where competitors may position their equipment.
- 4.10.3 The following non exhaustive list of equipment, shall be supplied by the Organising Authority for mounting on the aerial mast:
- a) Small Satellite Voice and Data Antenna
  - b) Standard Inmarsat C Antenna or similar
  - c) Microwave Antenna
  - d) Video Camera
  - e) Personal Locator Beacon direction finder
  - f) RF antenna
  - g) Large Satellite Voice and Data antenna

#### **4.11 Cockpit**

- 4.11.1 The cockpit is defined as a recess in the deck, aft of the main companionway (see rule 4.13), inboard of and below the adjacent sheer line. There shall only be one cockpit, which shall be open aft to the sea. No part of the cockpit sole shall be lower than 0.750m above DWL.
- 4.11.2 The cockpit shall completely drain at any angle of heel from 0 degrees up to and including 35 degrees. This shall be demonstrated during the Pull Down Test (Rule 8.8).

#### **4.12 Coach roof**

There shall only be one coach roof. The coach roof measured at 0.400m above RPU (see rule 7.5.3) shall have a minimum area of 7.50m<sup>2</sup> over a continuous length of not less than 3.500m measured externally. This area may include any hatch area that complies with the minimum height requirements. The coach roof shall not have through-holes for halyards and/or other control lines within 0.750m of the centre line aft of 0.500m behind the aft face of the mast.

#### **4.13 Companionway & Spray Dodger**

- 4.13.1 The main companionway shall be located at the aft face of the coach roof, with the aft most part of the hatch opening no less than 3.000m aft of the aft face of the mast. There shall be only one companionway entrance, which shall not extend more than 400mm below the local edge of the deck, or more than 600mm either side of the longitudinal centreplane of the boat. The companionway shall be fitted with a hatch capable of being opened, closed, and immediately secured from below decks and on deck. This hatch shall not open inwards, but may slide fore and aft, and may incorporate a washboard arrangement. Any companionway closure arrangement shall conform to ISO12216:2002: Small craft - Windows, Port-lights, hatches, deadlights and doors – Strength, watertightness requirements.

- 4.13.2 The companionway shall also be protected by a spray dodger of rigid construction, which shall provide unobstructed access between the companionway and the cockpit. With the spray dodger in its aft most position, it shall have a transverse section at or aft of the companionway not be less than 1.500m wide at a point 0.750m above RPU (see rule 7.5.3). The spray dodger may slide fore and aft, provided the minimum height is retained, but shall not be removable whilst racing except if specifically permitted in the Notice of Race. The spray dodger shall have no through-holes for halyards and/or other control lines. The spray dodger shall not be designed so as to interfere with other requirements of rule 4.13.1, specifically noting the requirement that the companionway hatch be capable of being opened, closed, and immediately secured from below decks and on deck.

#### **4.14 Transom**

Provision shall be made for two life rafts, as provided by the OA, to be mounted forwards of LLA, and aft of AFS, directly under the Aerial Mast (see rule 4.10) in a manner that allows the rafts to be rapidly deployed over the transom from within the lifelines or from the water by a single Crew Member with the boat at any angle of heel, including full inversion.

#### **4.15 Permitted Materials for Deck Equipment and Deck Fittings**

The following list of materials are permitted in the construction of Deck Equipment and Deck Fittings. Below deck components of deck equipment, such as steering systems, through deck fastenings, and other components which serve the sole purpose of allowing deck equipment to fulfil its function, are considered to be extensions of that equipment and therefore this rule shall apply to these parts.

- 4.15.1 5000 and 6000 series aluminium alloys, and equivalent alloys of other standards, e.g. BS, DIN, with a minimum specific gravity of 2.65.
- 4.15.2 Production isotropic cast aluminium alloys with a minimum specific gravity of 2.65.
- 4.15.3 Steel and steel alloys.
- 4.15.4 Moulded plastics.
- 4.15.5 Titanium alloys.
- 4.15.6 Carbon fibre and/or aramids. Cure temperature and fibre modulus are not restricted.
- 4.15.7 Wear pads which perform no function other than to prevent damage or wear to structure and/or deck gear may be of any material.

#### **4.16 Permitted Materials for Hull, Deck (including Spray Dodgers), Internal Structure & Internal Fittings**

The following list of materials are permitted:

- 4.16.1 Fittings may be constructed of 5000, 6000 and 7000 series aluminium alloys, and equivalent alloys of other standards, e.g. BS, DIN, with a minimum specific gravity of 2.65.
- 4.16.2 Fittings may be constructed of production isotropic cast aluminium alloys with a minimum specific gravity of 2.65.
- 4.16.3 Fittings may be constructed of steel and steel alloys.

- 4.16.4 Epoxy, polyester and vinylester resins, using cure and/or post cure temperatures no greater than 95<sup>0</sup>C, and applied pressure under vacuum not exceeding 0.98 atmospheres at STP at any time during the construction process, including post cures. Applied pressure under mechanical compression is not limited.
- 4.16.5 Glass fibres, aramid fibres and high strength carbon fibres (see rule 3.4).
- 4.16.6 Non-metallic honeycomb, closed cell PVC, SAN, polymethacrylimide or PET foam.
- 4.16.7 Wood.
- 4.16.8 Moulded plastics.

#### **4.17 High Visibility Markings**

- 4.17.1 To assist in SAR location, boats shall show on the coach roof, deck, cockpit sole, spray dodger or topsides, where it can best be seen from the air, one block of highly visible colour (e.g. day glow pink, orange or yellow) of at least 1m<sup>2</sup> in area.
- 4.17.2 At least 90% of the surface area of the rudder(s) shall be painted bright orange. The rudders should be repainted in the case of colour fade, wear and tear, or repair.
- 4.17.3 At least 5m<sup>2</sup> of the surface of the boat's hull, below DWL, shall be painted bright orange. This area shall be symmetrical about the boat's centre plane and shall be a single block of colour. This area should be repainted in the case of colour fade, wear and tear, or repair.

## 5 Structural Requirements

### 5.1 Structural Requirements

- 5.1.1 Attention is drawn to the Fundamental Rule Policy (see rule 1.1) and the Important Notice (see rule 1.2).
- 5.1.2 The structure shall be designed and constructed to meet the Essential Safety Requirement 3.1 given in Annex 1 of the Council of European Communities Recreational Craft Directive 94/25/EC for Boat Design Category A – Ocean.
- 5.1.3 International Standard ISO12215-5:2008 shall be used for conformity assessment, given in Chapter II and Annex VII of Directive 94/25/EC, except that examination by a Notified Body is not a requirement of the Volvo Open 70 Rule v.3. Nevertheless, the designer shall provide the Chief Measurer with calculations demonstrating compliance with the above standard. These calculations shall be provided in report form using the Wolfson HullScant software (Version 030609.FV20.2), and the associated .BST file .
- 5.1.4 If the Chief Measurer considers that he requires assistance in interpreting the technical documentation referred to in rule 5.1.3, it may seek outside opinion.

### 5.2 Minimum Panel Weights

Minimum panel weight requirements, excluding paint and fairing compound, are as follows:

- |       |  |      |                   |
|-------|--|------|-------------------|
| 5.2.1 | Hull bottom up to 300mm above DWL forward of MFS including the entire collision bulkhead.  | 11.0 | kg/m <sup>2</sup> |
| 5.2.2 | Hull bottom up to 300mm above DWL aft of MFS.  | 8.6  | kg/m <sup>2</sup> |
| 5.2.3 | Hull topsides and transom.   | 7.4  | kg/m <sup>2</sup> |
| 5.2.4 | Watertight sub-divisions including hatch panels.   | 6.5  | kg/m <sup>2</sup> |
| 5.2.5 | Deck, including cockpit sole & sidewalls, coach roof, spray dodger and hatch panels.   | 5.7  | kg/m <sup>2</sup> |
| 5.2.6 | All structural components of the retractable propulsion, and the daggerboard trunks forming the watertight envelope of the hull shall comply with Rule 5.2.2. In the case of the daggerboard trunks the applicable hull laminates shall apply up to the underside of the deck. |      |                   |

### 5.3 Panel Samples

- 5.3.1 Upon completion of the hull and deck, a post-construction inspection shall be carried out by the MG to take core samples.
- 5.3.2 A minimum of eight panel samples of 50mm minimum diameter shall be taken from positions as specified by and in the presence of a member of the MG. All samples shall be identified with the name of the boat and position from which the sample was taken. Additional samples may be taken at the discretion of the MG.
- 5.3.3 The samples shall comply with the minimum standards for panel weight. All samples shall be retained by the MG. Any shortfalls in panel sample weights shall be compensated for by the addition of extra laminate (either a unidirectional, multidirectional weave, scrim or

veil cloth), impregnated with a similar resin system as used for the basic construction of the boat. The MG may require further samples to be taken following the application of the additional laminate. Alternative methods of checking panel weight may be used at the MG's discretion.

#### **5.4 Watertight Sub-Division**

The boat shall be divided into at least six watertight sub-divisions, excluding tankage, with rigid bulkheads, each on a single transverse plane, in the following locations:

##### **5.4.1 Collision Bulkhead**

The bulkhead situated in the bow area is not required to be vertical. This bulkhead shall be constructed to hull bottom panel weight (see rule 5.2.1). The lowest point on the bulkhead shall be between 2.000m and 2.500m aft of LLF (see rule 7.3), measured on the centre line of the hull. If the upper forward point of the bulkhead meets the stem between 0.750m and 1.000m above DWL (see rule 7.2) then the hull construction standards within the collision chamber forward of and below the bulkhead need not apply. Otherwise the hull forward of and below the bulkhead shall be constructed to comply with the minimum panel weights as per rule 5.2.1.

##### **5.4.2 Forestay Bulkhead**

Entirely within 200mm of FFS (see rule 7.4.1) at the level of the edge of the deck. This bulkhead may be angled no more than 25 degrees from the vertical.

##### **5.4.3 Forward Bulkhead**

Entirely between 40% and 70% of the distance between FFS (see rule 7.4.1) and Middle Bulkhead at the level of the edge of the deck. This bulkhead may be angled no more than 25 degrees from the vertical.

##### **5.4.4 Middle Bulkhead**

All parts of the flat panel between 2.500m forward and 1.200m aft of MFS (see rule 7.4.2).

##### **5.4.5 Aft Bulkhead**

All parts of the flat panel forward of the rudder stock(s), and not less than 1.200m forward of AFS (see rule 7.4.3).

#### **5.5 Appendage Compartments**

- 5.5.1 The Ballast Keel canting mechanism, including keel pin bearings and cant actuators, shall be contained within a separate watertight compartment, or compartments which shall have watertight hatches to allow full access for adjustment and maintenance from inside the boat. Such hatches shall be a minimum of 300mm above DWL, shall be designed to withstand a minimum pressure of 40 kPa from within the compartment(s), and shall be designed such that visual inspection of the mechanism and clevis arrangement is possible without opening the hatches. These compartments shall be permanently fitted with breather pipes leading directly to the exterior of the boat so as to prevent excess pressure build up within the compartment(s). This compartment or compartments shall ensure that in the event of loss of the keel fin, the watertight integrity of the watertight sub-division can be maintained. Such compartments may utilise watertight bulkheads as required in rule 5.4 as boundaries.

- 5.5.2 Daggerboards shall be housed in trunks which are watertight between the hull/trunk interface and the deck/trunk. Such compartments may utilise watertight bulkheads as required in rule 5.4 as boundaries.

## 5.6 Sub-division Openings

- 5.6.1 All watertight bulkheads, with the exception of the Collision Bulkhead and the Forestay Bulkhead, shall have openings for access from adjacent sub-divisions, and shall have closures permanently attached by hinges.
- 5.6.2 The opening in the Forward and Middle Bulkheads shall not be less than 450mm above the inner skin of the hull at the local centreplane and shall open forwards.
- 5.6.3 The opening in the Aft Bulkhead shall not be less than 250mm above the inner skin of the hull at the local centreplane, and shall open aft.
- 5.6.4 Each opening shall be capable of being closed within 5 seconds and rendered watertight within 60 seconds.
- 5.6.5 Additionally there shall be through-bulkhead fittings on the forward, middle and aft bulkheads. These fittings shall be positioned or plumbed as necessary to allow the bilge to be pumped from the adjacent compartment to a level below the lowest edge of the bulkhead hatch without the need for the bulkhead hatch to be opened.
- 5.6.6 All bulkhead hatches and hatch arrangements shall be designed to withstand a pressure of 40 kPa applied from either side of the bulkhead.
- 5.6.7 Hatches in bulkheads shall be hinged and have adequate positive securing devices operable from both sides.
- 5.6.8 All of the watertight sub-divisions, excluding those forward of the Forward Bulkhead, shall have direct access through the deck, transom or cockpit area for the crew. Access shall be by hatches capable of being opened and immediately secured from either side, and shall conform to ISO12216:2002: Small craft - Windows, Port-lights, hatches, deadlights and doors – Strength, watertightness requirements. Any hinged hatches shall have the hinges located at the forward edge of the hatch. The companionway hatch may qualify as an access hatch.
- 5.6.9 No deck hatches shall open inwards excepting ports having an area of less than 0.071m<sup>2</sup>.
- 5.6.10 Deck, cockpit and transom hatches shall be so arranged as to be above the water when the hull is heeled 90 degrees.
- 5.6.11 At least one hatch shall permit entry to, and exit from, the hull when fully inverted, in measurement condition, with a minimum clearance of 150mm above the waterplane.
- 5.6.12 A cover, constructed of minimum deck panel weight shall be carried, such that in the event of a rig failure, the mast collar can be made watertight from the interior by securing the cover plate with permanently installed fixings.
- 5.6.13 Sealed skylights and deck prisms may be fitted in the deck and cockpit. They shall comply with ISO12216:2002: Small craft - Windows, Port-lights, hatches, deadlights and doors – Strength, watertightness requirements and the minimum panel weights in Rule 5.2.5.

## **6 Appendages**

An appendage is defined as an element which at any time extends from the hull or other appendage into the water for the purpose of increasing stability, generating lift, providing lateral area, and/or manoeuvring the Boat.

Appendages may be fitted and/or supported by self aligning bearings provided they are not specifically arranged so as to introduce a second angle of rotation. Any movement of a self aligning bearing must be consistent with correcting for either structural and/or building tolerances or deflection of the hull and/or appendage.

The following appendages are permitted:

### **6.1 Rudders**

- 6.1.1 Rudders shall rotate only, each about a single axis. This rule does not preclude the use of a system which allows a rudder to “kick up” and/or be removed and replaced in the event of damage or failure. A system of this type shall be sealed to prevent movement of the appendage in this secondary axis at all times whilst racing. This rule does not prohibit the use of weed cutting devices.
- 6.1.2 The number of rudders installed shall not exceed 2.
- 6.1.3 Rudders shall be aft of the aft bulkhead and forward of LLA.
- 6.1.4 Rudders shall have a lateral angle relative to the centreplane of the boat not greater than 30<sup>0</sup>, measured between any two points in a plane parallel to the maximum thickness of the rudder. This rule shall apply to any position within the full range of movement. Specifically, wings, end plates, boundary layer fences and hydroplanes are not permitted.
- 6.1.5 Each rudder shall be weighed and the weight recorded.

### **6.2 Daggerboards**

- 6.2.1 Daggerboards shall retract and extend only and shall not be designed to twist or rotate through the action of retraction or extension, nor rotate when under load. This rule does not prohibit self aligning bearings provided their movement is limited to correcting for deflections of the hull and/or daggerboard.
- 6.2.2 The number of daggerboards installed shall not exceed 2.
- 6.2.3 Both daggerboards shall be located in the same longitudinal position, which shall be forward of the aft bulkhead and aft of the forward bulkhead.
- 6.2.4 Daggerboards shall have a lateral angle relative to the centreplane of the boat not greater than 30 degrees, measured between any two points in a plane parallel to the maximum thickness of the daggerboard. This rule shall apply to any position within the full range of movement. Specifically, wings, end plates, boundary layer fences and hydroplanes are not permitted.
- 6.2.5 The draft, position and weight of daggerboards shall be measured and recorded.
- 6.2.6 The daggerboard trunks in the hull shall not be fitted with any closing device.

### 6.3 Ballast keel

- 6.3.1 Exceptionally, RRS 51 and RRS 52 shall not apply in respect of canting keels.
- 6.3.2 The total weight of the assembled keel fin and ballast bulb shall not exceed 7400 kgs. This weight shall include all bulb attachment fastenings, all adjustment shims if fitted to achieve certificate recorded draft, fairings, filler and paint. This weight shall not include the main canting rotation pin, or any canting mechanism attachment bolts or pins.
- 6.3.3 The weight of the bare steel fin keel (FW) shall not be less than 1900 kgs. This weight shall not include the main canting rotation pin(s) nor any canting mechanism attachment bolts or pins nor any ballast bulb fastenings. Any additional weight needed to make up the weight to 1900kgs shall be made with a lead ballast block permanently fastened to the bulkhead above the canting keel watertight compartment.
- 6.3.4 In the case of a Volvo Open 70 v.2 Boat; the original fin keel may continue to be installed (on that Boat only). As for a version 3 Boat, the total weight of the assembled keel fin and ballast bulb shall not exceed 7400 kgs. If the original fin was lighter than 1900 kgs and the total weight of the assembled keel fin and ballast bulb was less than 7400 kgs any weight added to the bulb shall be matched by an equivalent weight being added inside the hull. As for a version 3 Boat the keel fin must comply with the load cases in Rule 6.4.
- 6.3.5 Only one ballast keel shall be installed.
- 6.3.6 The ballast keel may be canted transversely up to a maximum of 40 degrees each side of the centreplane. The canting mechanism shall be fitted with metal collars which limit cant angle of the fin to 40 degrees at any time whilst racing. The collars shall not be less than 30mm long as shown in the sketch below. The collars shall be made on materials which will permanently deform if the cant angle exceeds 40 degrees from the centreplane at any time..

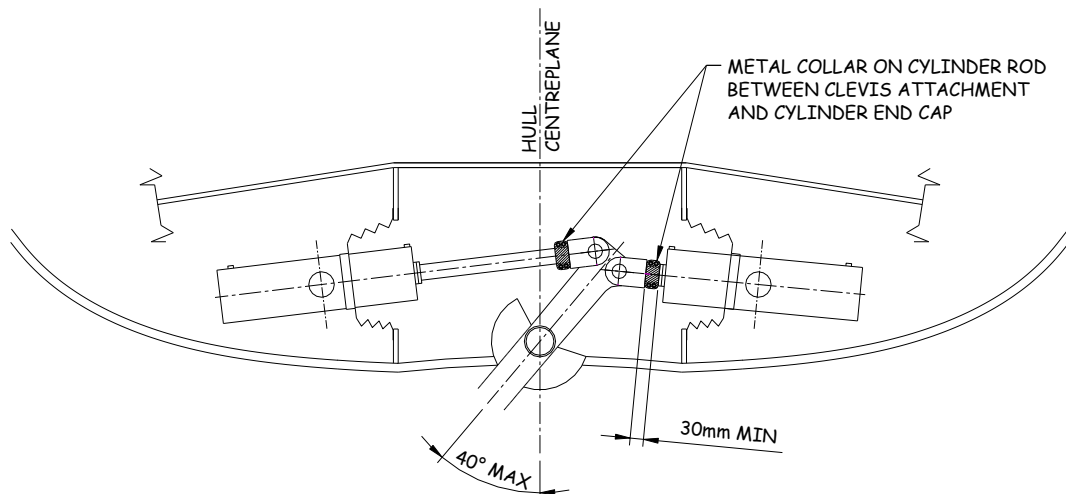

- 6.3.7 The canting mechanism shall have a permanently installed manually operated override system to enable the keel angle to be adjusted throughout its full range of movement by hand. There shall be two independent canting systems, each of which shall be independently capable of withstanding Load Case 1 (see rule 6.4.1), with the keel canted in any orientation. One cant actuator shall be mounted to port and the other to starboard of the centreplane.

- 6.3.8 The ballast keel shall rotate about the centreplane, parallel to DWL. The central axis of the pin shall be located within 150mm of the local hull surface or fair projection of the local hull surface in any transverse section, bridging any hollows in the surface of the hull (see rule 4.4.3).
- 6.3.9 There shall be a system installed in the canting mechanism, which upon activation shall return the keel to the centreplane, with an appropriate damping mechanism to ensure sufficient righting moment is retained throughout the manoeuvre, and with a speed that allows the crew to regain control of the Boat as quickly as possible without exerting extreme, potentially damaging loads on the Boat. This system shall be operable from each helm position and below decks, and shall not require either engine to be started for it to operate.
- 6.3.10 Only one keel fin is permitted. Only steel or steel alloys are permitted in the basic structure of the keel fin including fin/bulb attachments and fin/hull attachments. The keel fin, including the lever arm for the attachment of the cant mechanism clevis arrangement, shall be solid steel except as permitted in Rule 6.3.11. The solid steel shall be free from empty spaces and cavities except in way of connections to the hull, cant mechanism, the slot for the aft edge fairing spine and to the bulb, which shall be no larger than best practice requires for the fastenings.
- 6.3.11 The aft most 35% of the local chord length of the fin keel in section may be fitted with a composite fairing. This fairing may be engaged in a slot in the aft edge of the steel fin. This slot shall not exceed 25mm deep x 10mm wide.
- 6.3.12 Any closing plates and/or fairing plates shall be rigidly fastened directly to either the hull, keel fin or the ballast bulb and shall not be designed to flex or deform as the keel cants. Specifically, wings, end plates, boundary layer fences and hydroplanes are not permitted.

#### **6.4 Load case requirements for the keel, canting mechanism & associated structure**

The complete ballast keel and bulb assembly and appendage compartment, including canting mechanism, hydraulic components including hydraulic hoses and bearing arrangements, shall be designed and constructed to withstand the following load cases using factors of safety at least as high as given below:

##### **6.4.1 Load Case 1**

Stresses shall be calculated for the keel fin sections, each cant mechanism and the associated internal structure, due to the transverse bending moments and shear forces that arise with the keel and bulb horizontal and out of the water. The minimum factor of safety for the associated stresses in this load case shall be 3 based on the yield stress or proof stress of permitted metals or the ultimate strength of fibre reinforced composite materials.

##### **6.4.2 Load Case 2**

Calculations shall be made for the longitudinal bending moments and shear forces that arise from a horizontal Load of  $3 \times W$  (see rule 8.5) acting forwards and aft applied through a line of action 300mm above the base of the bulb in the plane of the fin, with the keel canted in any orientation. The minimum factor of safety for the associated stresses in this load case shall be 1.3 based on the yield stress or proof stress of permitted metals or 3 based on the ultimate strength of fibre reinforced composite materials.

##### **6.4.3 Load Case 3**

Calculations shall be made for the bending moments and shear forces that arise from a vertical Load of  $1.5 \times W$  (see rule 8.5) acting upwards and downwards applied to the base of the bulb, with the keel canted in any orientation. The minimum factor of safety for the

associated stresses in this load case shall be 1.3 based on the yield stress or proof stress of permitted metals or 3 based on the ultimate strength of fibre reinforced composite materials.

- 6.4.4 For design purposes the tensile yield strength or proof stress is not to be taken as greater than 390MPa for steel and steel alloys.
- 6.4.5 The calculations of Load Cases 1, 2 and 3 shall be presented to the Chief Measurer to demonstrate compliance with this rule using the calculation result sheet provided in Appendix B. The MG shall inspect the bare steel element to check dimensions, weight against the information provided for compliance with this rule prior to fairing and painting.

## **6.5 Permitted Materials for Rudders & Daggerboards**

The following list of materials are permitted in the construction of any part of the rudders and daggerboards

- 6.5.1 5000 and 6000 series aluminium alloys, and equivalent alloys of other standards, e.g. BS, DIN, with a minimum specific gravity of 2.65.
- 6.5.2 Production isotropic cast aluminium alloys with a minimum specific gravity of 2.65.
- 6.5.3 Steel and steel alloys.
- 6.5.4 Epoxy, polyester and vinylester resins, using cure and/or post cure temperatures no greater than 125<sup>o</sup>C.
- 6.5.5 Glass fibres, aramid fibres and High Strength carbon fibres (see rule 3.4).
- 6.5.6 Closed cell PVC, SAN, polymethacrylimide or PET foam.
- 6.5.7 Wood.
- 6.5.8 Moulded plastics.

## **6.6 Permitted Materials for Ballast Keel Fin (excluding canting mechanisms & systems)**

- 6.6.1 Only steel and steel alloys are permitted in the structure of the keel fin, including fin/bulb attachments and fin/hull attachments. This requirement shall apply to all components connecting the fin to the boat including pins, bolts, and bearing plates/brackets which attach the fin to the hull structure. This material rule does not apply to bearings, bearing liners and bearing damping/restraint systems, which may be of any material except titanium, magnesium, cobalt or aluminium alloys. The use of surface fairing, filling and painting materials no greater than a total thickness of 5mm, measured normal to the surface is permitted.

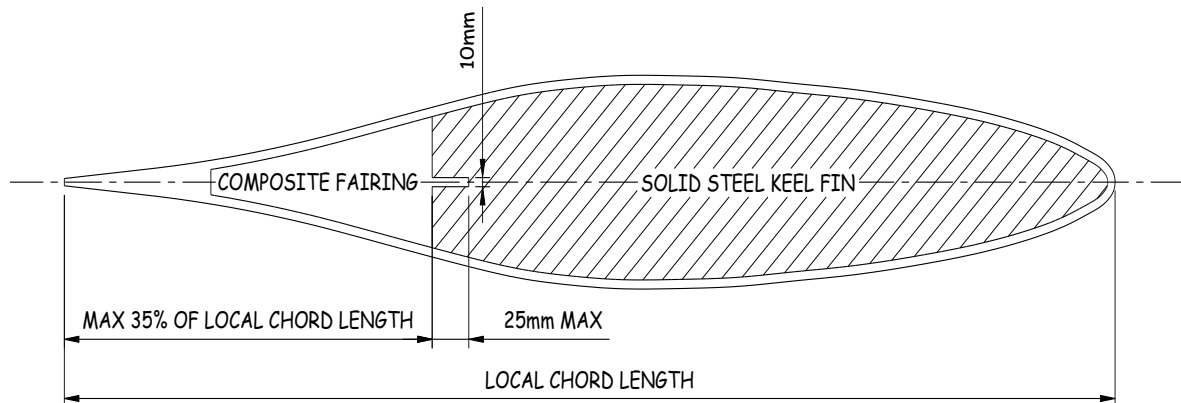

- 6.6.2 Secondary heat treatment methods which alter the properties of a steel alloy by way of reducing resistance to corrosion in sea water and/or reduce fatigue resistance properties in variations in sea water temperature around 10<sup>0</sup>C are not permitted.
- 6.6.3 Non-structural fairings, which perform no task other than improve the hydrodynamic characteristics of the keel fin, may be constructed using any materials permitted for the construction of rudders and daggerboards (see rule 6.5).
- 6.6.4 Non-structural cover plates and spacers, which perform no task other than improve the hydrodynamic characteristics of the fin to hull intersection, may be constructed using any materials permitted for the construction of rudders and daggerboards (see rule 6.5).

## 6.7 Permitted Materials for Keel Bulb

- 6.7.1 Lead alloy with a specific gravity not greater than 11.34 is permitted in the keel bulb only. No other part of the keel assembly shall be constructed using lead alloy. Voids in the bulb may be filled with any material which has a specific gravity not greater than 11.34.
- 6.7.2 Steel and steel alloys.
- 6.7.3 Non-structural cover plates may be constructed using any materials permitted for the construction of rudders and daggerboards (see rule 6.5).

## 6.8 Permitted Materials for Ballast Keel canting mechanisms & systems

Only steel and steel alloys are permitted in the canting mechanisms and systems, including trunions and clevises. This does not apply to bearings, manifolds, seals, pipes, pumps, reservoirs, hoses and non-structural linings, which may be of any material except titanium, magnesium or cobalt alloys. Electrical components may be made of any material. Housings or assemblies which are rigidly attached to the boat's structure, and which support and/or restrain the trunions or trunion bearings are not part of the canting mechanism system and as such are limited by Rule 4.16.

## **7 MEASUREMENT ASHORE (see Figure 1)**

### **7.1 Ashore Measurement Condition**

On completion and assembly of the hull, deck, bulkheads and all structural components, before fitting of appendages and spars, a post-construction inspection and measurement of the hull shall be carried out by the MG.

### **7.2 Design Water Line (DWL)**

The Boat shall be set up ashore level athwartships and on the horizontal DWL which shall be declared by the designer prior to measurement.

### **7.3 Length of Hull (LH)**

LH shall be recorded as the horizontal distance between LLF and LLA. LLF shall be defined as the forward most point of the hull, excluding fittings, bowsprit and local reinforcement. LLA shall be defined as the aft most point of the hull excluding fittings, local reinforcement and emergency steering system fixings (see rule 15). Neither fittings nor local reinforcement shall be used to extend the sailing length of the Boat beyond LH. LH shall not be greater than 21.500m.

### **7.4 Stations**

There shall be three measurement stations established in vertical transverse sections of the Boat, as defined below:

- 7.4.1 Forward Freeboard Station (FFS). FFS shall be established at a distance 1.000m aft of LLF.
- 7.4.2 Mid Freeboard Station (MFS). MFS shall be established at a distance 10.500m aft of LLF.
- 7.4.3 Aft Freeboard Station (AFS). AFS shall be established at a distance 1.500m forward of LLA.

### **7.5 Measurement Reference Points**

Measurement reference points shall be permanently marked at the time of measurement with a cross-head screw as follows:

- 7.5.1 RPF shall be marked on the centre line of the stem at a recorded height, preferably 400mm above DWL, which can practically serve as a permanent reference.
- 7.5.2 RPS shall be marked on the centre line of the stem at a recorded height, preferably 1000mm above DWL, which can practically serve as a permanent reference.
- 7.5.3 RPU shall be marked at MFS on the edge of the deck.
- 7.5.4 RPL shall be marked at MFS on DWL.
- 7.5.5 RPA shall be marked on or near the centre line of the transom at a recorded height, preferably 400mm above DWL, which can practically serve as a permanent reference.
- 7.5.6 RPD shall be marked on or near the centre line of the deck at a recorded horizontal distance aft of LLF, preferably at 2.000m, which can practically serve as a permanent reference.

**7.6 Freeboards**

Freeboards (FFM, MFM and AFM) shall be the vertical distance from the edge of the deck to DWL, and shall not be less than 1.900m, 1.595m and 1.400m respectively. The values of FFM, MFM and AFM shall be recorded port and starboard at the three measurement stations, FFS, MFS and AFS.

**7.7 Maximum Beam (B)**

The maximum beam of the Boat, excluding any toe rails, fittings, or appendages measured horizontally in any transverse section, shall not be greater than 5.700m nor less than 5.300m.

**7.8 Draft (D)**

Draft shall be the maximum draft below DWL of any appendage throughout its range of movement. Draft shall not be greater than 4.500m. For the purpose of draft measurement the Boat shall be set up level to DWL both fore and aft and athwartships without rig tension, and with the weight distributed between the keel and the hull to replicate the measurement afloat condition as closely as possible. The draft will be measured by reference to the RPL (see rule 7.5.4).

**7.9 Keel Weight (KW)**

The Ballast Keel shall be weighed complete as ready to be fitted to the Boat for racing. It shall include all fin/bulb fastenings and all fairings and weed cutting devices (if fitted when racing). It shall exclude all removable components of the fin/hull bearing and pin arrangement. KW shall not be less than 6000kg nor greater than 7400kg.

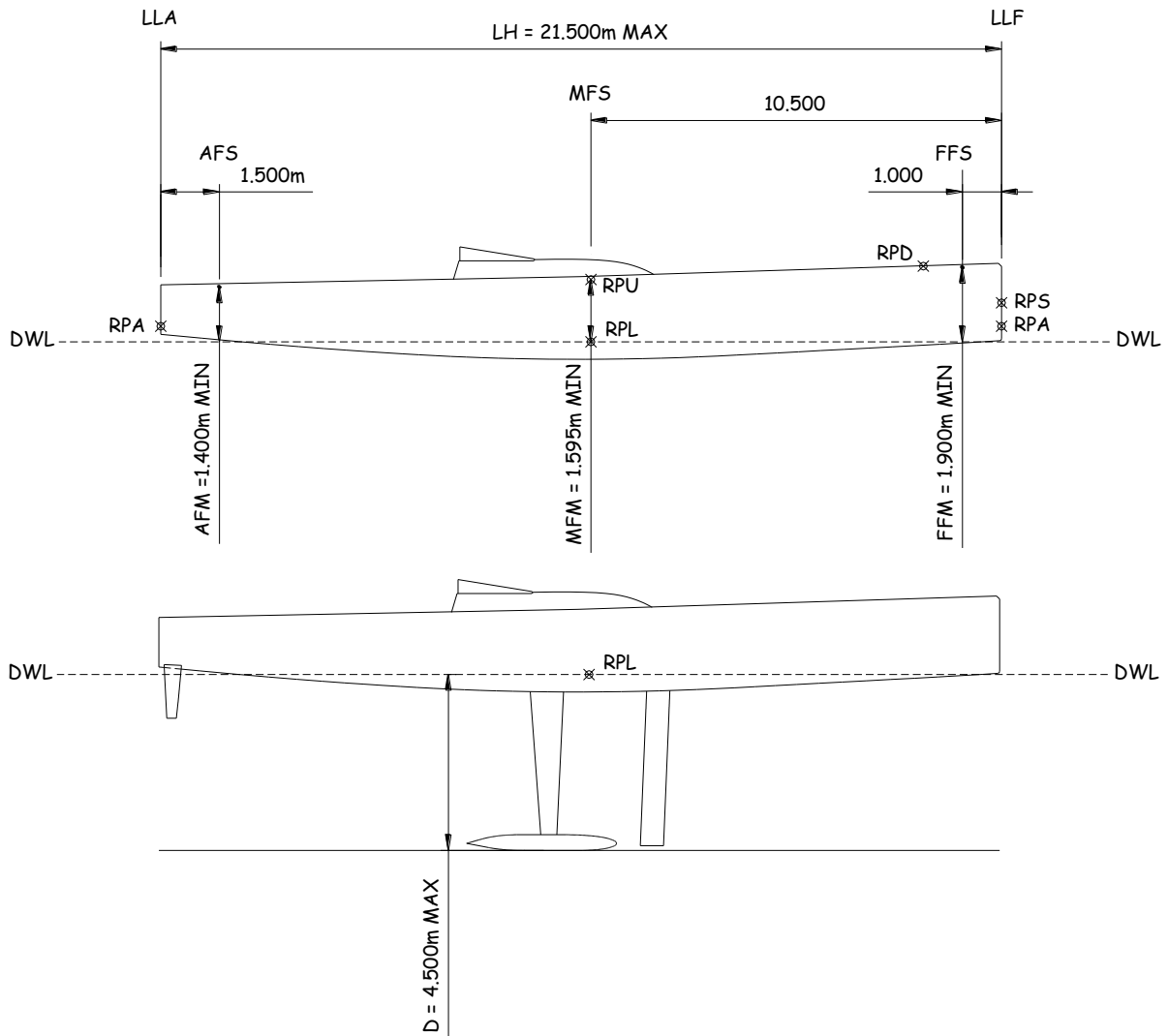

**Figure 1 Hull and Draft Measurement**

## **8 MEASUREMENT AFLOAT**

### **8.1 Measurement Afloat**

The Boat shall be complete, with all fittings, fixings and equipment (including that stipulated in Rules 12, 13 & 14) installed, except for the following, which shall be removed:

- 8.1.1 All sails.
- 8.1.2 All removable safety equipment, excluding lifelines and jack stays.
- 8.1.3 Crew Members.
- 8.1.4 Fuel, water and the contents of any other tanks (excluding: engine lubricants, cooling fluids and hydraulic systems, which shall be maintained at serviceable levels, as recommended by the manufacturer).
- 8.1.5 Food, cooking and catering utensils.
- 8.1.6 Anchors, chains, warps, mooring lines and fenders.
- 8.1.7 Clothing, bedding and personal effects.
- 8.1.8 Tools and spare parts.
- 8.1.9 All deck equipment with the exception of padeyes, winches, tracks, grinder pedestals (including handles, gears and shafts), wheel pedestals (including wheels and all steering cables, blocks and quadrants), cheek blocks, jammers and any other items that remain rigidly fixed (bolted, bonded and/or screwed). Deck equipment secured with rope or webbing may be removed.
- 8.1.10 All running rigging except one headsail halyard, topmast backstays, runners and checkstays, including flying blocks (but excluding tails).
- 8.1.11 This list is not exhaustive. Any additional item that is not considered to be part of the Boat, when equipped for racing, shall be removed.
- 8.1.12 All items of electronics, navigation and communication equipment including all installed OA supplied equipment are considered part of the Boat and shall remain onboard, with the exception of spares.

### **8.2 Specific Gravity (SG)**

The specific gravity of the water, taken approximately 300mm below the surface, shall be recorded as SG.

### **8.3 Sink**

Any variation from the standard SG of 1.025 shall be used to correct measured freeboards using a rate of 0.25mm per 0.001 of SG. This correction shall also be applied to the measurement of the height of RPF (see rule 7.5.1) and RPA (see rule 7.5.5) relative to the water surface.

#### 8.4 Weighing

The Boat shall be capable of being lifted from a single lifting point in measurement afloat condition and shall be weighed using a certified load cell which has been approved in writing by the Chief Measurer. All sea cocks and valves at through-hull openings shall be open.

#### 8.5 Weight of Boat (W)

In measurement afloat condition (see rule 8.1), W shall not be less than 14000kg nor greater than 14500kg.

#### 8.6 Floatation

- 8.6.1 Immediately following weighing (see rule 8.1), the height of RPF and RPA shall be measured above the MWL. The height of both RPF and RPA above MWL shall be equal to or greater than their respective heights above DWL (see rule 7.5)
- 8.6.2 At the time of Floatation the daggerboards shall be in their fully retracted position.
- 8.6.3 Trim variation at RPF and RPA between DWL and MWL shall not be greater than 30mm over LH.

#### 8.7 Canting Keel Angle

To ensure compliance with rule 6.3.6, the cant angle shall be measured. The ballast keel may be canted transversely up to a maximum of 40 degrees each side of the centreplane. The canting mechanism shall be fitted with metal collars which limit cant angle of the fin to 40 degrees at any time whilst racing. The collars shall not be less than 30mm long as shown in the sketch below. The collars shall be made on materials which will permanently deform if the cant angle exceeds 40 degrees from the centreplane at any time.

#### 8.8 Pull Down Test

- 8.8.1 Condition: The Boat shall be in a minimum of Measurement Afloat Condition, except that one canting mechanism shall be either removed from the Boat, disabled or disconnected to the extent that it does not contribute to restraining or controlling the keel. Additional running rigging and deck equipment may also be on board as necessary, along with up to eight personnel including a member of the MG.
- 8.8.2 Pull Down Test Procedure
  - Step 1. With a halyard attached to a strong point ashore and the bow and stern secured, the keel is canted fully towards the strong point, allowing the slack in the halyard to be taken up and the Boat heeled. The bow and stern line are to be adjusted as necessary to restrain the Boats position as appropriate.
  - Step 2. The halyard is then wound down to heel the Boat to approximately 50 degrees. The heel angle is recorded.
  - Step 3. The automatic keel centring system (rule 2.14.4(f)) shall then be activated to demonstrate compliance. The heel angle is recorded.
  - Step 4. The keel shall then be canted further until it has completed the full range of movement, with the full 40 degree cant to "windward" meeting a point where the keel is horizontal along its central plane. The heel angle is recorded.
  - Step 5. The automatic keel centring system (rule 6.3.9) shall then be activated to demonstrate compliance.

Step 6. The keel is then lowered further until the Boat returns to position 2. and is then returned to upright.

Step 7. The opposite canting mechanism is reinstalled, and the first is disconnected/disabled/removed. The test shall then be repeated, heeling the Boat in the same direction.

At the MG's discretion, the tests may then be repeated with the Boat heeled in the opposite direction.

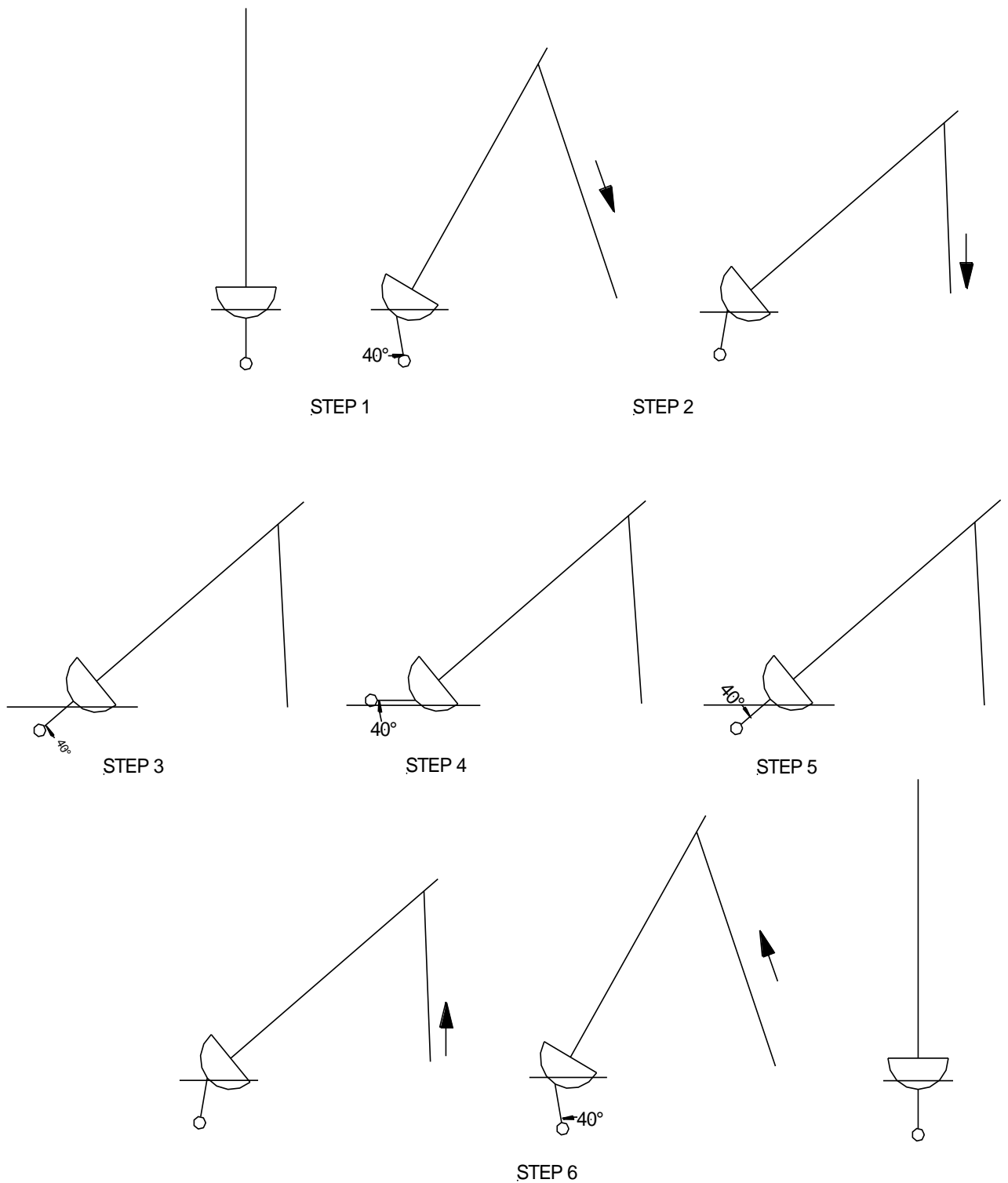

***Pull Down Test Diagram***

## **9 STABILITY**

### **9.1 Damaged Stability**

- 9.1.1 With any single compartment free flooding, the designer shall show by calculation that the minimum height of the deck above the damaged condition water plane will not be less than 500mm, with 0 degrees keel cant. Calculations demonstrating compliance with rule shall be submitted to the Chief Measurer. Calculations shall be based on the Boat being in the following condition:
- a) Total weight to equal  $W+2750\text{kg}$ .
  - b) Longitudinal Centre of Buoyancy and Vertical Centre of Gravity of  $W$  to be calculated by the designer.
  - c) Longitudinal Centre of Gravity of the 2750kg required in 9.1.1(a) shall be 1.500m aft of MFS. Vertical Centre of Gravity of the 2750kg required in 9.1.1(a) shall be 400mm above DWL.
- 9.1.2 The buoyancy inherent in the skin of the hull in way of the flooded compartment may be taken into account. The buoyancy of the internal structure shall not be included.
- 9.1.3 The contribution to buoyancy of all tankage shall be ignored.
- 9.1.4 At the discretion of the Chief Measurer, any single compartment, except the main accommodation area, may be required to be flooded to a level 150mm above the top of any openings for access from adjacent compartments, or 750mm above DWL, whichever is the greater, to ensure the structural integrity of the watertight sub-division. Prior to this test sufficient time shall be provided to protect items against water damage. Additional sealant and or bracing around hatches is not permitted.

### **9.2 Angle of Vanishing Stability (AVS)**

AVS is defined as the heel angle at which the righting arm (GZ) falls to zero, and shall not be less than  $115^{\circ}$ . The designer shall calculate the righting arm curve for the Boat with all tanks empty in the condition defined in rule 8.1. All moveable appendages shall be considered attached and fixed as per the worst case condition. The designer shall, make a declaration of AVS to the Chief Measurer. At the discretion of the Chief Measurer, additional information and/or measurements may be required to verify AVS.

## 10 **RIG MEASUREMENT (see Figure 2)**

### 10.1 Rig Limitations

- 10.1.1 Only one mast is permitted. The mast shall be stepped with the base fitting (if installed in the mast and included in the mast weighing condition (see rule 10.2)) or end of the mast tube no higher than 550mm above MWL. The mast shall not be permanently bent in its unloaded state, nor shall it be designed and/or rigged to rotate or twist under Load. The base of the mast tube shall be securely fastened to the mast step or adjoining structure, in such a way that it can not move fore and aft, athwartships nor vertically whilst racing.
- 10.1.2 The mast and mast position shall be fixed at the step and the deck, other than a natural linear movement at the deck not exceeding 5mm in any direction.
- 10.1.3 Other than local stiffening, the external mast dimensions below the top of IG (see rule 10.7) shall not be less than 300mm fore and aft by 150mm wide, or greater than 375mm fore and aft by 180mm wide. For the purposes of this rule, local stiffening is considered to be any reinforcement added to the exterior of the mast tube in the immediate vicinity of a fitting, or group of fittings. Such material shall be no larger than is necessary to relieve stress concentrations.
- 10.1.4 The mast groove or track shall not move relative to the mast section, and shall be included in the mast fore and aft dimensions.
- 10.1.5 Headfoils or similar permanently installed headsail luff support devices are not permitted on the forestay.
- 10.1.6 The mast shall be supported by a permanent forestay and permanent shrouds. All connections or adjustment shall be at or above the local edge of the deck, with the exception of the forestay and any inner forestay(s), which may be attached in recesses (see rule 4.6.4). Additional standing and running rigging is allowed. Standing rigging chainplates shall be fitted wholly within the sheerline. Adjustment of the permanent forestay, shrouds, spreaders, diamond or jumper struts and any other side standing rigging while racing is not permitted and all means of adjustment shall be positively locked, except where specifically permitted in rule 10.1.8. Adjustment of inner forestays is permitted.
- 10.1.7 No two elements of the standing rigging, of the same vertical height, shall be parallel, or near parallel, between termination and/or diversion points, unless the horizontal clearance between the elements is greater than 300mm. For this purpose and rule 10.16.3, a single element is considered to include any collection of fibres housed within a braided cover. The individual wires, fibres and/or pultruded rods within the braided cover are not considered to be individual elements.
- 10.1.8 Devices for measuring standing rigging tension are permitted provided that they are incapable of being used to adjust the standing rigging.
- 10.1.9 The mast may be steadied to balance a slackened backstay and running backstays either by the use of headsail or spinnaker halyards and their proper winches, or by a strop attached to the deck aft of FFS taking tension on an articulated forestay. The forestay shall be permanently attached at the deck and at the IG point (see rule 10.7). Inner forestay(s) shall be permanently attached at the mast below the IG point, and may be detachable at the deck, but shall not be attached forward of the forward end of J.
- 10.1.10 No standing rigging shall be attached to the mast below a point 3.800m above Mast Datum (MD) (see rule 10.3). Deck spreaders are not permitted.

- 10.1.11 No standing rigging shall pass from or through the mast tube to a standing rigging spreader above that point on the mast tube, except for jumper/diamond shrouds, where the jumper/diamond struts attach to the mast tube at or above the IG point.
- 10.1.12 Halyard locks to reduce halyard tension are permitted but must be capable of reliable engagement and disengagement by a crew member on deck.
- 10.1.13 Curved spreaders are not permitted. A line shall be drawn between the leading edge of the spreader base at the mast tube (projected as necessary) and the centre line of the cap-shroud attachment point of that spreader. At no point shall this line fall outside of the rigid body of the spreader.
- 10.1.14 Any backstay(s), running backstay(s) and checkstay(s) fitted at any time whilst racing shall be permanently attached at the mast tube termination and shall not be detached, retracted or lowered from that attachment point at any time whilst racing.
- 10.1.15 Spinnaker poles and jockey poles are not permitted.

## **10.2 Mast Weight (MWT) & Centre of Gravity (MCG)**

The mast shall be weighed in the condition defined below, the mast shall not weigh less than 625kg and shall have a centre of gravity not less than 12.000m above mast datum (MD)(see rule 10.3). The condition when weighed shall only include the following:

- 10.2.1 All standing rigging (diameters and materials will be recorded) spreaders, jumpers, diamonds, backstays, running backstays including flying blocks (but excluding runner tails), checkstays, instrument sensors and read-outs, antennae, radar, lights, cables, integral hydraulic rams and pipework, and items which remain attached to the mast when the mast is removed from the Boat.
- 10.2.2 All fittings required to sail the Boat including integral mast jacks, headboard car and mainsail sliders, and brackets and toggles for vang and boom. The vang including associated hydraulic rams and pipework, and boom shall not be included in mast weight.
- 10.2.3 All other running rigging shall be removed and may be replaced by messengers of not more than 3mm diameter and of sufficient length only to re-lead the running rigging.
- 10.2.4 For the purpose of establishing the centre of gravity all rigging shall be pulled down and secured, the headboard car shall be in its raised position, and all other fittings shall be set at their lowest positions.

## **10.3 Mast Datum (MD)**

MD shall be measured from DWL (see rule 7.2) and MD shall not be greater than 2.500m. MD shall be marked as the top edge of a permanent 30mm measurement band.

## **10.4 Mainsail Hoist (P)**

P shall be measured from MD to the highest level to which the head of the mainsail may be hoisted. The top of P shall be marked as the lower edge of a permanent 30mm measurement band. P shall not be greater than 29.000m.

**10.5 Mast Position (MP)**

The horizontal distance from LLF (see rule 7.4.1) to the forward face of the mast at MD shall not be greater than 10.500m, with the mast in it's fixed position as specified in rule 10.1.2.

**10.6 Base of Foretriangle (J)**

J shall be measured horizontally from the forward face of the mast at MD to the intersection of the centreline of the tensioned forestay with the deck. J shall not be greater than 9.500m, with the mast vertical, or as close to vertical as possible if set with permanent rake.

**10.7 Height of Foretriangle (IG)**

IG shall be the height measured from MD to the highest point of the intersection of the centre line of the forestay with the front of the mast or the permanent bearing surface, including any halyard keepers/deflectors, of any headsail halyard when held at right angles to the mast. IG shall not be greater than 25.500m.

**10.8 Masthead Spinnaker Hoist (ISP)**

Masthead spinnaker hoist shall be measured from MD to the underside of the masthead spinnaker halyard when held at right angles to the mast, with halyard locks employed if installed. ISP shall not be greater than 29.000m.

**10.9 Fractional Spinnaker Hoist (IFR)**

Fractional spinnaker hoist shall be measured from MD to the underside of the fractional spinnaker halyard when held at right angles to the mast, with halyard locks employed if installed. IFR shall not be greater than 26.200m.

**10.10 Chain Plate Width (CPW)**

The minimum V1 shroud base between the centres of the cap shroud tangs at the deck shall not be less than 4.000m.

**10.11 Boom Measurement**

The top edge of the boom shall be straight within a tolerance of 20mm between points 500mm from the extreme ends of the boom. The cross section of the boom including chafe guards shall not exceed 400mm at any point, in any orientation. Localised fittings and stiffening, such as vang lugs and padeyes, including any associated reinforcement are not included in the above maximum dimensions, with the exception of chafe guards. For the purposes of this rule, local stiffening is considered to be any reinforcement added to the exterior of the boom tube in the immediate vicinity of a fitting, or group of fittings. Such material shall be no larger than is necessary to relieve stress concentrations. Outriggers and/or diamond struts are not permitted on booms. The weight of the boom shall be measured and recorded.

**10.12 Mainsail Foot Length (E)**

E shall be measured, with the top edge of the boom perpendicular to the aft face of the mast, from the aft face of the mast at BAD, ignoring any mainsail track or luff groove, to the forward edge of a permanent 30mm measurement band, of contrasting colour, beyond which the mainsail clew point shall not be set. E shall not be greater than 8.500m.

### 10.13 Boom Above Datum (BAD)

BAD shall be the vertical distance from MD to a fair extension of the top of the boom or boom track, when perpendicular to the aft face of the mast. BAD shall not be less than 1.000m. BAD shall be marked as the top edge of a permanent 30mm measurement band of contrasting colour.

### 10.14 Bowsprit Length (BSL)

- 10.14.1 BSL shall be the horizontal distance from LLF to the extremity of the bowsprit. BSL shall not be greater than 1.820m.
- 10.14.2 The bowsprit shall be of a fixed length, and shall not be designed to articulate, retract or rotate.
- 10.14.3 A lazy sheet keeping device may extend beyond the forward end of the bowsprit, and providing it serves no purpose other than to prevent the lazy sheet from falling under the bowsprit, is not bound by Rules 10.14.1 & 10.14.2.
- 10.14.4 A fixed, non-adjustable bobstay is permitted, which shall be attached on centreplane. The lower attachment point of any bobstay shall be no larger than required and shall not obstruct RPF (see rule 7.5.1). The bobstay shall comply with the standing rigging requirements as set out in Rule 10.16
- 10.14.5 The vertical height of the bowsprit excluding the bobstay shall not exceed 400mm.

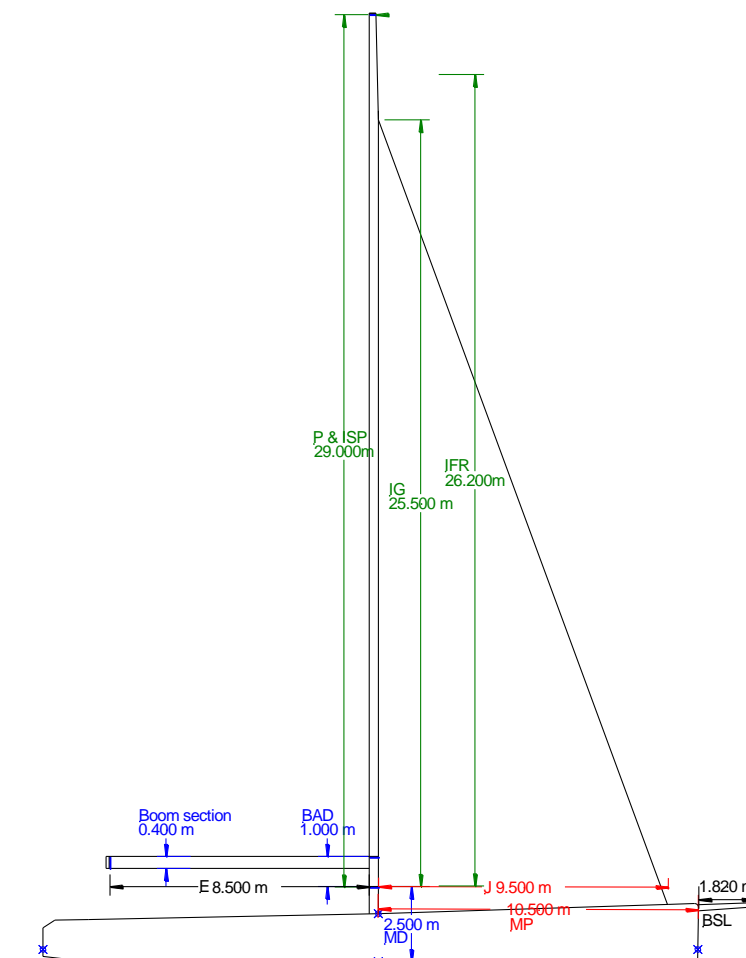

**Figure 2 - Rig Measurement**

**10.15 Permitted Materials for Mast, Spreaders, Jumper Strut(s), Boom, Bowsprit & associated standing & running rigging fittings.**

The following list of materials are permitted in the construction of any part of the spars:

- 10.15.1 5000 and 6000 series aluminium alloys, and equivalent alloys of other standards, e.g. BS, DIN, with a minimum specific gravity of 2.65.
- 10.15.2 Production isotropic cast aluminium alloys with a minimum specific gravity of 2.65.
- 10.15.3 Nitronic 50, stainless steel (including 17/4 PH),
- 10.15.4 Titanium and titanium alloys.
- 10.15.5 Epoxy, polyester and vinylester resins, using cure and/or post cure temperatures no greater than 125<sup>o</sup>C.
- 10.15.6 Glass fibres, aramid fibres and High Modulus carbon fibres (see rule 3.4).
- 10.15.7 Moulded plastics.
- 10.15.8 All spars may be constructed using syntactic core materials, consisting of microspheres loaded into a polymeric binder, provided any such core material has a density of not less than 300kg/m<sup>3</sup>, and the total thickness of the core is not greater than the total thickness of the fibre reinforced laminate walls.
- 10.15.9 Spreaders and bowsprits may be constructed using closed cell PVC, SAN, polymethacrylimide or PET foam core.
- 10.15.10 Booms may be constructed using closed cell PVC, SAN, polymethacrylimide, PET foam core and/or non-metallic honeycomb core.

**10.16 Permitted Materials for Rigging & Associated Fittings**

- 10.16.1 All standing rigging shall be constructed of Nitronic 50, Aramid, Intermediate Modulus PBO (see rule 3.4), Intermediate Modulus carbon fibres (see rule 3.4), Vectran® and/or Dyneema®. This rule does not prohibit the use of polyester and/or polymers in non-structural covering and braiding for protection against abrasion, impact and UV degradation.
- 10.16.2 All running rigging shall be constructed of aramid, Vectran®, Dyneema®, polyethylene, polyester, Intermediate Modulus PBO (see rule 3.4), and/or Intermediate Modulus carbon fibres (see rule 3.4).
- 10.16.3 Standing rigging shall be nominally circular in section, except at mast, spreader and strut intersections, where the sectional shape shall not be limited within 500mm of an intersection point.

## 11 SAIL MEASUREMENT (see Figure 3)

- 11.1.1 ERS shall apply for sail measurement unless otherwise prescribed in the Volvo Open 70 Rule v.3. All sails shall be measured and signed by a member of the MG who may refuse to certificate or sign any sail which he considers circumvents the sail limitations or requirements of the Volvo Open 70 Rule v.3 in any way.

### 11.2 Mainsail

- 11.2.1 No more than 12 battens may be used, each on a line intersecting both the luff and the leech and capable of being passed through a 150mm diameter circle.
- 11.2.2 Mainsail Leech Length (MLE) shall be recorded as the distance between the head point and the clew point. MLE shall not be greater than 29.00m.
- 11.2.3 Mainsail Cap Width (MCW) shall be recorded as the distance from the luff to the leech measured perpendicular to the luff 500mm below the head point.
- 11.2.4 Mainsail Upper Width (MUW) shall be recorded as the shortest distance between the upper leech point (7/8th height) and the luff.
- 11.2.5 Mainsail Three-Quarter Width (MTW) shall be recorded as the shortest distance between the three-quarter leech point and the luff.
- 11.2.6 Mainsail Half Width (MHW) shall be recorded as the shortest distance between the half leech point and the luff.
- 11.2.7 Mainsail Lower Width (MLW) shall be recorded as the shortest distance between the quarter leech point and the luff.
- 11.2.8 Mainsails shall have provision for at least one slab-reef, which shall be capable of reducing the mainsail area by a minimum of 15%.
- 11.2.9 Mainsail Area (MSA) shall be calculated for each mainsail using the formula below, and marked prominently at the tack with the area:

$$\text{MSA} = 29.75 + 7 \times \text{MLW} + 7 \times \text{MHW} + 5.25 \times \text{MTW} + 4.532 \times \text{MUW} + 2.783 \times \text{MCW}$$

- 11.2.10 MSA shall not be greater than 175.00m<sup>2</sup>.

### 11.3 Spinnaker

- 11.3.1 RRS 50.4 shall not apply. A spinnaker shall be declared as a spinnaker at the time of measurement, and shall not be hoisted above the top of ISP (see rule 10.8).
- 11.3.2 Battens are not permitted in spinnakers.
- 11.3.3 Spinnaker Foot Length (SF) shall be recorded as the distance between tack point and clew point.
- 11.3.4 Spinnaker Half Width (SHW) shall be recorded as the distance between the half points of the luff and leech measured along the shortest path on the surface of the sail.
- 11.3.5 Spinnaker Luff Length (SLU) shall be recorded as the distance between the head point and the tack point.
- 11.3.6 Spinnaker Leech Length (SLE) shall be recorded as the distance between the head point and the clew point.

- 11.3.7 Spinnaker Area (SPA) shall be calculated for each spinnaker using the formula below, and marked prominently at the clew with the area:

$$\text{SPA} = (\text{SLU} + \text{SLE}) \times \text{SF} / 4 + (\text{SHW} - \text{SF} / 2) \times (\text{SLU} + \text{SLE}) / 3$$

- 11.3.8 Masthead spinnakers shall not be hoisted above the top of ISP. SPA; shall not be less than 300.00m<sup>2</sup> nor greater than 500.00m<sup>2</sup>.
- 11.3.9 Fractional spinnakers shall not be hoisted above the top of IFR (see rule 10.9). SPA shall not be greater than 350.00m<sup>2</sup>
- 11.3.10 Reefing of spinnakers is permitted. Snuffer, squeezer, or other furling device for spinnakers are permitted.

#### 11.4 Headsail

- 11.4.1 RRS 50.4 shall not apply.
- 11.4.2 A headsail shall be declared as a headsail at the time of measurement.
- 11.4.3 No more than 4 battens may be used.
- 11.4.4 Headsails shall be tacked aft of the forestay and forward of the mast.
- 11.4.5 Headsails shall not be hoisted above the top of IG.
- 11.4.6 For a headsail, luff perpendicular (HLP) shall not be greater than 13.00m.
- 11.4.7 Headsails may be furled and/or reefed.

#### 11.5 Staysails (SS)

- 11.5.1 RRS 50.4 shall not apply.
- 11.5.2 An SS shall be declared as an SS at the time of measurement.
- 11.5.3 No more than 4 battens may be used.
- 11.5.4 SS's shall be tacked aft of the forestay and forward of the mast.
- 11.5.5 SS's shall not be hoisted above the top of IG.
- 11.5.6 SS Area (SSA) shall be calculated for each SS using;

$$\text{SSA} = \text{LP} \times \text{LL} \times 0.5.$$

Where LL and LP are the luff length and the length from the luff to the clew perpendicular to the luff respectively.

- 11.5.7 SSA shall not be greater than 60.00m<sup>2</sup>.
- 11.5.8 SS's may be furled and/or reefed.

### 11.6 Heavy Weather Jib (HWJ)

- 11.6.1 RRS 50.4 shall not apply.
- 11.6.2 A HWJ shall be declared as a HWJ at the time of measurement.
- 11.6.3 No more than 4 battens may be used.
- 11.6.4 HWJs shall be tacked aft of the forestay and forward of the mast.
- 11.6.5 HWJs shall not be hoisted above the top of IG.
- 11.6.6 HWJ Area (HWJA) shall be calculated for each HWJ using

$$\text{HWJA} = \text{LP} \times \text{LL} \times 0.5.$$

Where LL and LP are the luff length and the length from the luff to the clew perpendicular to the luff respectively.

- 11.6.7 HWJA shall not be greater than  $94.00\text{m}^2$ , and the sail shall be made of appropriate materials of strength and weight suitable for its intended use.
- 11.6.8 HWJ's may be furled and/or reefed.

### 11.7 Storm Jib

- 11.7.1 RRS 50.4 shall not apply.
- 11.7.2 A storm jib shall be declared as a storm jib at the time of measurement.
- 11.7.3 No more than 4 battens may be used. The leech shall not have positive roach
- 11.7.4 Storm jibs shall be tacked aft of the forestay and forward of the mast.
- 11.7.5 Storm jibs shall not be hoisted above the top of IG.
- 11.7.6 Storm jib area (SJA) shall be calculated for each storm jib using

$$\text{SJA} = \text{LP} \times \text{LL} \times 0.5$$

Where LL and LP are the luff length and the length from the luff to the clew perpendicular to the luff respectively.

- 11.7.7 SJA shall not be less than  $30.0\text{m}^2$  nor greater than  $35.0\text{m}^2$ , with a maximum LL of 17.00m. Storm jibs shall be made of Spectra® or similar materials suitable for its intended use, with minimum weight of  $400\text{gm}/\text{m}^2$ .
- 11.7.8 Storm jibs shall be constructed from highly visible coloured material or have a highly visible coloured patch of area no less  $14\text{m}^2$  added to each side. The recommended colours are orange, dayglo pink or yellow.

### 11.8 Storm Trysail

- 11.8.1 The storm trysail shall be capable of being sheeted independently of the boom and shall be between  $36\text{m}^2$  and  $41\text{m}^2$  in area. Area shall be calculated as leech length x leech perpendicular x 0.5. It shall have neither headboard nor battens. The sail numbers and letter(s) of the boat shall be placed on both sides of the trysail in as large a size as practicable. The trysail shall be made of Spectra® or similar material suitable for storm use with minimum weight of  $400\text{gm}/\text{m}^2$ .

- 11.8.2 The storm trysail shall be constructed from highly visible coloured material or have a highly visible coloured patch of area no less 14m<sup>2</sup> added to each side. The recommended colours are orange, dayglo pink or yellow.
- 11.8.3 The Storm Trysail shall be used in cases of safety or emergency and sheeted without a mainsail.
- 11.8.4 The Storm trysail shall not have positive roach on the leech or the foot.

### **11.9 Sail & Deck bags**

Sail or deck bags shall be constructed to ensure the rapid draining of water in all circumstances and adequate arrangements shall be provided for their secure stowage on deck. The use of pulpit or stanchion bases as tie down points is prohibited.

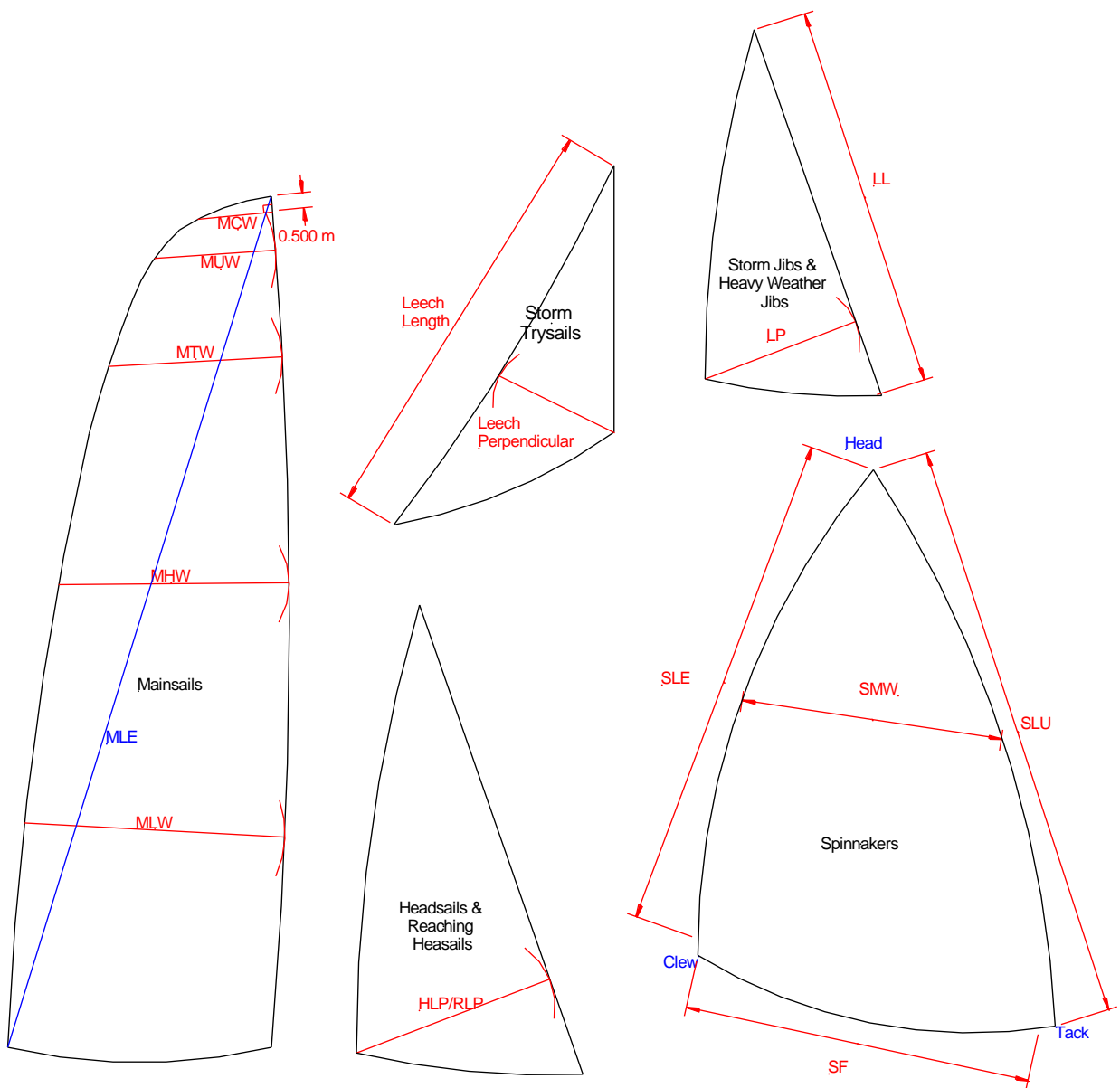

**Figure 3 - Sail Measurement**

### **11.10 Sail Setting Restrictions**

- 11.10.1 All sails shall be set consistent with measurement. No part of any sail may be detachable. Artificially thickened sails and multiple surface sails, whether inflated by the action of the wind or otherwise, are not permitted (except as specifically permitted in rule 11.11.4). This rule does not prohibit reefing of sails as specifically permitted in rules 11.1.8, 11.2.10, 11.3.7, 11.4.8, and 11.5.8.
- 11.10.2 All sails shall be flown in close proximity to the Boat. Mainsails shall be flown with the luff between the top of P and the BAD band and the foot within E.
- 11.10.3 RRS 50.1 shall not apply.

### **11.11 Permitted Materials for Sails**

- 11.11.1 Sails may be made of any soft materials (see ERS), except carbon fibre and/or PBO.
- 11.11.2 Titanium alloys are permitted in rings and cringles attached to the sail.
- 11.11.3 Titanium alloys and/or carbon fibre are permitted in headboards.
- 11.11.4 Battens may be constructed of any material. Inflatable battens are not permitted.

## **12 ACCOMMODATION**

### **12.1 Practical Requirement**

- 12.1.1 Cabin space, required accommodation and equipment, and associated fittings shall be practical in use, fully operational, readily accessible, functional, designed to minimise the risk of physical injury and permanently fitted while racing, as appropriate. All required equipment shall be of a size and capacity adequate for the intended use. If in any doubt over what will be accepted, it is recommended that a request for interpretation be submitted in accordance with rule 2.3.
- 12.1.2 Compartments for stowage shall not retain water and shall be designed and constructed to retain their contents in the event of a capsize.
- 12.1.3 The cabin sole, where fitted, shall be designed and constructed to remain in position in the event of a capsize. Any openings in the cabin sole larger than 0.0125m<sup>2</sup> shall have a hinged or tethered cover.
- 12.1.4 No component required by rule 12 shall be installed forward of the forward bulkhead (see rule 5.4.3) or aft of the aft bulkhead (see rule 5.4.5).

### **12.2 Berths**

- 12.2.1 A minimum of 10 individual berths shall be permanently installed.
- 12.2.2 Berths may taper as required by hull shape and internal structures, but shall have a minimum width of not less than 300mm, and a minimum length of 1.900m and maximum width not less than 600mm.
- 12.2.3 The minimum vertical clearance over half the length of any berth, with all berths in the horizontal position, shall be 500mm.
- 12.2.4 All berths shall be measured within any hard edge or surround.
- 12.2.5 All berths shall be separated by rigid partitions, or shall be individual pipe cots.

### **12.3 Equipment Stations**

- 12.3.1 A single surface navigation table suitable for its purpose, with adequate storage for charts and navigation equipment, with a seat and seated headroom of not less than 1.050m shall be installed. The navigation table shall have a minimum area of 0.84m<sup>2</sup>, and shall have minimum dimensions of 0.600m x 1.400m, excluding any fiddles or other obstructions. The navigation table shall be fully accessible from the seating area.
- 12.3.2 A media station with a seat and seated headroom of not less than 1.050m shall be installed. There shall be a single surface media desk or similar fully accessible from the seating area. The media desk will be supplied by the OA and shall have external dimensions of (XXX)m x (XXX)m x (XXX)m high, and may have an integral hinged lid. Opposite the seating area, above the media desk, there shall be a single surface rectangular, rigid back plate for additional media equipment, which shall be a minimum of 1.100m x 0.400m high. The rigid back plate shall be mounted in a position which does not impede full opening of the media desk lid to gain access to the media equipment. The media desk lid hinges shall not be removed.
- 12.3.3 The Media and Navigation stations shall be separate and arranged to ensure that each may be accessed and used independently and that the use of one shall in no way interfere with the use of the other.

## 12.4 Galley

- 12.4.1 A galley shall be permanently installed with a minimum of two gimballed gas burners. If fitted, an oven shall be counted as one gas burner.
- 12.4.2 The stove shall be securely installed against a capsize with safe accessible fuel shut-off control capable of being safely operated in a seaway.
- 12.4.3 Any compartment in which gas is stowed or used shall have an overboard drain or be monitored by an effective gas detector with an audio alarm.
- 12.4.4 Gas bottles may be carried below decks only in the following circumstances:
  - a) If they are directly connected to the burner of a cooker.
  - or
  - b) If they are spare and not connected to any device and do not rely on a valve to maintain their gas-tight integrity.
- 12.4.5 A minimum of one sink shall be installed in the galley area. This shall be fitted with a freshwater inlet and a saltwater inlet. Through-hull drainage from the sink shall be used and fitted with a non-return valve at the hull termination, which shall be readily accessible from the galley area without need for removal of any cabin sole or galley fittings. The sink shall have a minimum capacity of 10litres.
- 12.4.6 The work area of the galley shall be appropriate in size for the hygienic and safe preparation of food. The work area shall be a minimum of 900mm above the local cabin sole. Handrails shall be located as appropriate in the galley area.

## 12.5 Toilet

- 12.5.1 A sea water toilet, separately plumbed in accordance with local regulations or with a catchment tank shall be fitted. Skin fittings shall be below the static water line. The toilet shall be securely installed in a self contained, rigidly constructed compartment, separated from the main cabin by rigid partition or bulkhead, which shall not be part of a larger area used for other purposes such as sleeping, food preparation, sail handling or stowage. The compartment shall be accessible through a fitted door or other permanently fitted means of closing, of appropriate size, which may be made of soft fabric, provided it can be fully closed by means of zip or similar device.
- 12.5.2 An additional sink is required, separate from the galley. This sink shall be in the toilet compartment and shall be fitted with a dedicated freshwater and/or saltwater inlet. Through-hull drainage from the sink shall be used and fitted with a non-return valve at the hull termination, which shall be readily accessible. The sink shall have a minimum capacity of 10litres.

## 12.6 Emergency Equipment Lockers

- 12.6.1 Two watertight lockers of rigid construction, solely for the stowage of emergency equipment, shall be permanently installed between the aft bulkhead and the middle bulkhead. If desired the two lockers may be incorporated into one locker. The combined volume of the lockers shall not be less than 330 litres and neither shall be less than 130 litres. One of the lockers shall be able to house the large emergency 100 litre per day watermaker which is xxxmm x xxxmm x xxxmm. Additionally the lockers shall be able to

house both of the large medical kit Pelican or similar cases. The dimensions and the weight of the Cases will be given in the Notice Of Race Appendix B.

- 12.6.2 These lockers shall be located such that they are accessible at all times and can be rapidly opened and sealed when closed using cable-tie type seals. The interior of the lockers shall not be interrupted by any internal structure. Sufficient suitable anchorage points shall be provided to ensure the contents are securely stowed within the locker(s).
- 12.6.3 The emergency equipment lockers shall be practical in use, functional and designed to accommodate all the required emergency equipment

## **12.7 Interior colour**

To aid visibility for both the crew and media requirements, the interior of the boat between 2.000m forward of MFS (see rule 7.4.2) and the Aft Bulkhead shall be covered with paint, vinyl, decals, or a combination of the three. This covered area shall include at least 90% of the exposed surfaces of the deck head, floorboards, hull inner skin and engine boxes. The colour shall be optimised to increase the interior light for filming purposes. Team graphics and logos may be applied, provided the overall effect is sufficient for media purposes. Subsequent to the application of paint, vinyl, or decals, this requirement does not address general wear and tear. The interior colour should be maintained as necessary to meet the needs of this rule.

## **13 Tanks & Water Makers**

### **13.1 Location**

All tanks shall be rigid in construction and shall not extend more than 1.000m outboard of the centre line of the boat.

### **13.2 Freshwater Tanks & Water Makers**

Two freshwater tanks, of no less than 100litre nor greater than 150litre capacity each, shall be installed symmetrically about the centreplane. A power driven water maker with a minimum nominal output of 20litres per hour shall be permanently installed and plumbed to the freshwater tanks. Freshwater tanks shall not be used for liquids other than drinking water, and shall not be filled, emptied or transferred for the purpose of altering trim or stability.

### **13.3 Fuel Tanks**

13.3.1 All fuel tanks shall be pressure tested to 25kPa. Fuel tank pressure test certificates, shall be made available to the MG. Fuel tanks shall not be used for liquids other than fuel, and shall not be filled, emptied or transferred for the purpose of altering trim or stability. The following fuel tanks shall be fitted:

- a) A fuel tank or tanks having a total capacity of not less than 230litres, installed symmetrically about the centreplane.
- b) A day tank with a minimum capacity of 10litres, positioned close to and such that a gravity feed of fuel to the auxiliary engine is achieved. The day tank shall be constructed of stainless steel.
- c) A separate fuel tank for emergency use only, installed symmetrically about the centreplane. This tank shall be capable of isolation from the main fuel system and have a capacity of not less than 120litres. All inlets and outlets shall be capable of being sealed, using a cable-tie type seal. The tank shall have an upper inspection opening allowing dip stick access.

13.3.2 No fuel tank shall form a structural part of the boat.

### **13.4 Aft Ballast Tank**

13.4.1 Exceptionally, RRS 51 shall not apply in respect of the aft ballast tank.

13.4.2 A single aft ballast tank is permitted. This tank, if fitted, shall be aft of the Aft Bulkhead and symmetrical about the centreplane. The tank shall be rigid, integral to and within the hull.

13.4.3 The ballast tank may be fitted with baffles. These baffles may restrict, but shall not prevent the movement of water within the tank in any direction.

13.4.4 The maximum volume of the ballast tank, including all pipework, shall be 1600litres.

13.4.5 The ballast tank shall be filled and emptied by use of direct drain, venturi systems or manual pumps, with no assistance from powered pumps.

13.4.6 A drainage mechanism shall be fitted to allow the ballast tank to be completely discharged overboard in the event of a full inversion.

- 13.4.7 The aft ballast tank shall be measured using a certified flow-meter to ensure compliance with rule 13.4.4.

## **14 ENGINES, PROPELLER & EQUIPMENT**

### **14.1 Main Engine Installation**

- 14.1.1. A Volvo Penta D2-75 marine diesel engine (ON 869648) shall be installed including a connection kit (ON 21157312) on the centre line of the boat with the crankshaft fore and aft and the flywheel aft. The position of the engine shall be in accordance with the provisions of rule 14.3. The engine shall be fitted close-coupled with a Volvo Penta marine reduction transmission MS25A-A ratio 2.74:1 (ON 3582635). The engine and transmission shall be flexibly mounted.
- 14.1.2. The engine and transmission is to be connected to a propeller using a 31.75 mm diameter 316 stainless steel (or equivalent material) shaft via a constant velocity joint or double universal joint. The shaft shall also be fitted with a thrust bearing to transfer propeller thrust to the hull structure. The shaft shall be fitted with a bearing, stern tube and seal. Neither: titanium, cobalt, magnesium, carbon nor aluminium alloys shall be used in any mechanical components of the propulsion system except those components supplied as part of the engine and equipment by Volvo Penta. The distance between the mid-length of the shaft bearings shall not exceed 1800 mm. A 3 bladed Nibral fixed pitch propeller with a diameter not less than 550 mm shall be fitted to the outboard end of the shaft.
- 14.1.3. When deployed the propeller shaft inclination shall not exceed 12 degrees from DWL and there shall be a minimum clearance of 50mm between the closest point on the locus of the rotating propeller blades and the closest part of the hull or closing plates.
- 14.1.4. The propulsion system may be retractable into the surface of the hull. If such a retractable propulsion system is installed, it shall utilise a CV joint or double universal joints to permit the shaft line to rotate relative to the engine crankshaft for the system to be retracted into the hull. The system shall be designed such that it can be retracted into the hull without the need for the addition/removal of components or the need for manual alignment.
- 14.1.5. The propulsion system shall be able to be deployed from its retracted position inside the hull to locked down and fully operational with the propeller rotating under power in 30 seconds whilst the boat is moving forward at 10 knots.
- 14.1.6. At the discretion of the Chief Measurer and/or OA, the boat may be required to demonstrate that, in measurement afloat condition (see rule 8.1) plus no less than 500kg of equipment and crew, the boat is capable of achieving a minimum speed under power of 9.0 knots without wind assistance in fair conditions. If conditions are unfavourable the MG reserves the right to withhold the certificate of a Boat until a time as this can be demonstrated.
- 14.1.7. A Volvo Penta button panel kit (ON 21144348), tachometer kit (ON 21234535, ON 874708 & ON 3886666) and 2 units of the Volvo Penta 3m extension cable (ON 3842733) or longer, shall be fitted in a position not directly exposed to sea water.
- 14.1.8. A throttle and gear lever shall be installed in a position where the helmsman can easily operate it. Volvo Penta control (ON 1140093 & ON 1140095) with neutral safety switch (ON 855352) may be used.
- 14.1.9. The main engine shall be fitted with all the Volvo Penta supplied auxiliaries. Additional auxiliaries shall be driven from the front end by a shaft or a belt driven pulley or a combination of the two. Any drive shaft connected directly to the engine shall be connected by two universal couplings and approved torsional damping device.

## 14.2 Auxiliary Engine Installation

- 14.2.1 A Volvo Penta D1-30 marine diesel auxiliary engine (ON 869645) shall be installed, including connection kit (ON 21157299). A Volvo Penta button panel kit (ON 21144348), tachometer kit (ON 21234535, ON 874708 & ON 3886666) and 2 units of the Volvo Penta 3m extension cable (ON 3842733), or longer, shall be fitted in a position not directly exposed to sea water.
- 14.2.2 The auxiliary engine shall be fitted with all the Volvo Penta supplied auxiliaries, with the exception of the engine mounted flywheel coupling if not required. Additional auxiliaries shall be driven from the flywheel by a shaft and shall not be fitted directly on the auxiliary engine.
- 14.2.3 Any drive shaft connected directly to the auxiliary engine shall be connected by two universal couplings, and approved torsional damping device. Arrangements for driving additional auxiliaries shall be designed to ensure that no significant loads other than torque loads are applied to the engine crankshaft.

## 14.3 Engine Weight Distance (EWD)

Engine Weight Distance (EWD) shall be the horizontal distance of the centre of the main engine block (mid-way between the second and third cylinders at cylinder head level) from the aft face of the mast at deck level. EWD shall not be less than 3.300m nor greater than 3.800m.

## 14.4 Machinery Installation General Conditions

- 14.4.1 Engine installations shall be in accordance with the Volvo Penta Installation Manual. All installations shall be approved by a Volvo Penta engineer nominated by the Organising Authority. All installations shall comply with good engineering practice, as defined by Volvo Penta. Retractable propeller systems shall also be approved by Volvo Penta before manufacture for approval of hydrodynamic characteristics and effects.
- 14.4.2 Only modifications to specified machinery approved by the Chief Measurer are permitted. The Chief Measurer may only approve modifications in exceptional circumstances. Modifications that result in lighter specified machinery will not be approved. All items supplied by Volvo Penta are governed by this rule.
- 14.4.3 Both the main and auxiliary engines are to be installed within a closed and rigid box(s) so that both engines, when running, can be securely covered. The fuel and exhaust systems shall be securely installed and adequately protected from the effects of heavy weather. The box(s) shall be capable of retaining a gas fire-extinguishing medium for sufficient time to permit an engine fire to be extinguished. The box(s) shall be fitted with suitable arrangements for the introduction of a fire-extinguishing medium. The box(s) shall be designed to provide adequate access for service and ventilation according to the installation manual.
- 14.4.4 Both engines shall be fitted with separate, permanently installed (not portable) wet exhaust systems which discharge directly overboard. Both systems shall be designed to minimise the risk of sea water entering either engine, by use of a non return valve or hull surface exhaust cover flap. Volvo Penta silencers (ON 842768 (main engine) & ON 828837 (Auxiliary engine)) or Chief Measurer in consultation with Volvo Penta, approved alternatives shall be used. Both engines shall be fitted with Volvo Penta flexible exhaust hose between engine and silencer (ON 1140667 (main engine) & 1140665 (auxiliary engine)) or Chief Measurer, in consultation with Volvo Penta, approved alternatives.
- 14.4.5 A separate fuel filter for each engine (ON 877766) or Chief Measurer, in consultation with Volvo Penta, approved alternatives shall be installed between the fuel tank(s) and each

engine. Fuel lines shall be installed in accordance with ISO7840:2004 Small craft- fire resistant fuel hoses, and meet the European Boat Safety Directive Regulation 94/25/EC.

14.4.6 Each engine shall be fitted with separate, permanently installed, water intake systems that may be connected to one through-hull fitting with individual sea cocks or non-return valves. Any such sea cock shall have the attached pipe perpendicular to the surface of the hull or angled forward to minimise the intake pressure. The water intake for each engine shall be situated within 1.000m of EWD (see rule 14.3) The engine through-hull fitting shall not be used for any other equipment. A Volvo Penta water strainer (ON 3583840 (main engine) & ON 21219693 (auxiliary engine)) or Chief Measurer, in consultation with Volvo Penta, approved alternatives shall be fitted between the through hull fitting and each engine. An anti-siphon valve, or equivalent system, shall be fitted for each engine.

14.4.7 Both engines shall be available for immediate use at all times. The propulsion system shall be prepared for deployment and engagement to the main engine at all times, so that it can be rapidly deployed in the event of an emergency.

#### **14.5 Alternators**

At least two additional engine driven alternators shall be carried. One alternator shall be capable of being installed to operate on the auxiliary engine. The main engine will be supplied with brackets for the fitting of an extra 24V alternator. Half of the capacity of the alternators shall be capable of meeting all the electrical requirements of the boat, including Organising Authority requirements.

#### **14.6 Batteries, Fuses & Switches**

14.6.1 All batteries shall be installed inside a waterproof enclosure(s) vented to atmosphere with non-conductive inner linings, capable of being easily sealed against movement and able to withstand a full inversion. The total weight of batteries fitted shall not be less than 280kg, nor greater than 350kg.

14.6.2 All electrical circuits shall be fitted with appropriate fuses or circuit breakers. Appropriate switches shall be installed to enable all electrical circuits to be isolated from batteries and alternators. The voltage of any onboard systems shall not exceed 50v.

#### **14.7 Bilge Pumps**

14.7.1 Two manual bilge pumps shall be permanently installed, one operable from above deck and the other operable from below deck. The bilge pumps shall conform to the relevant parts of International Standard ISO 15083:2003 Small craft- bilge pumping systems.

14.7.2 Unless permanently fitted, each bilge pump handle shall be attached with a lanyard or catch or similar device to prevent accidental loss.

14.7.3 At least two powered bilge pumps shall be carried. Their total documented capacity shall not be less than 500LPM at 2m head, and they shall be carried and ready for deployment at all times. For each pump carried there shall be a permanently installed, dedicated connection terminal with a direct connection to the batteries (see rule 14.6) that shall be mounted at least 700 mm above DWL. It will be demonstrated, at the request of the MG, that all pumps are capable of discharging water from each of the watertight sub-divisions (see rule 5) except for that forward of the Collision Bulkhead (see rule 5.2). Access to any flooded compartment shall be through the interior. For the purposes of rule 8.1 (Measurement Afloat condition) the powered bilge pumps, including hoses and fittings may be removed, however the dedicated connection terminals shall remain onboard.

- 14.7.4 All bilge pumps shall discharge either directly overboard, through the cockpit sides or through the deck. Bilge pumps shall not discharge into the keel wetbox or below the waterline.

#### **14.8 Renewable Energy Source**

The Boat shall be fitted with a renewable energy source device capable of delivering 80 watts of electrical power to the electrical system. These systems could include solar power, wind power, or a water flow energy device. The device shall be wired into the Boat's electrical system and shall provide power whenever available from the device.

## **15 EMERGENCY STEERING SYSTEM**

### **15.1 Emergency Steering System**

- 15.1.1 Each Boat shall carry an emergency steering system.
- 15.1.2 All components of the emergency steering system which are dismantled when the system is not in use shall be stored in a designated position or positions which shall be forward of the aft bulkhead, if stowed below decks, and not aft of LLA if stowed on deck.
- 15.1.3 The emergency steering system may only be used for emergency purposes, i.e. when the main rudder system has failed. The rudder blade(s) shall not be permanently mounted and may only be installed and used in the event of failure of one or both of the main rudder blades.
- 15.1.4 Appropriate means of locking the blade in place shall be provided. The tiller may be detachable from the rudder assembly and may also serve as the main emergency tiller. In this case, an appropriate method of locking the tiller to the rudder shall be provided. The tiller may consist of a number of sections to facilitate installation and to permit convenient steering around other fittings such as guardrails, the radar post, etc.
- 15.1.5 The emergency steering system may facilitate aspects of the main rudder system, provided all parts of the main rudder system are duplicated in the emergency steering system package, so that in the event of the entire main rudder system failing, including housings, it can be completely replaced with the emergency steering system.
- 15.1.6 The organising authority may require a demonstration that the emergency steering system is properly designed for purpose and capable of steering the Boat in a seaway.
- 15.1.7 The complete assembly, including transom mounted gudgeons and/or bearing mechanism, blade, stock, tiller, and all fixings shall not weigh less than 75kg.

### **15.2 Permitted Materials for Emergency Steering Systems**

The emergency steering system may be constructed from any materials permitted for the construction of rudders and daggerboards (see rule 6.5).

**Appendix A****Volvo Open 70 Class Insignia**

The class insignia shall be no less than 4.0m high, excluding any background, and scaled for width accordingly.

The class insignia shall be placed as close to the top of the mainsail as reasonably possible leaving a gap no less than 0.30 m between the insignia and the top of the mainsail. The class insignia may be placed at the same height on both sides of the mainsail. The background area of the insignia shall be such that the reverse insignia can not be seen through the sail.

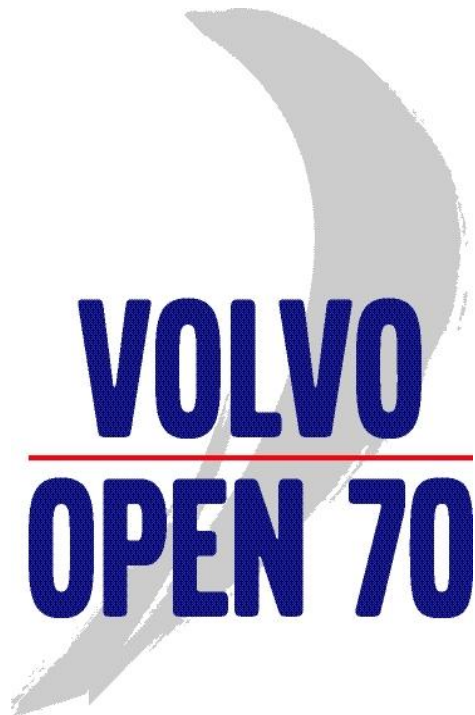

Diagram 1: Positive variant on a light background

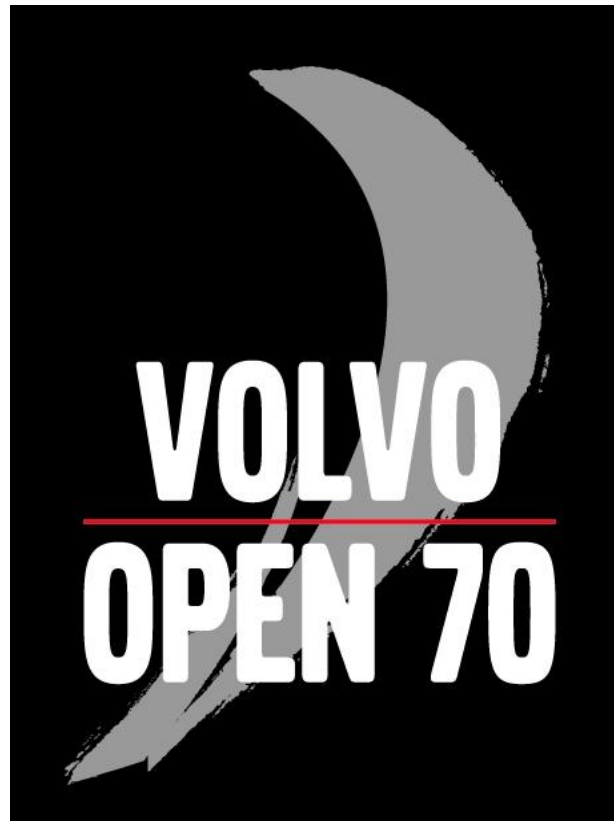

Diagram 2: Negative Variant on dark background

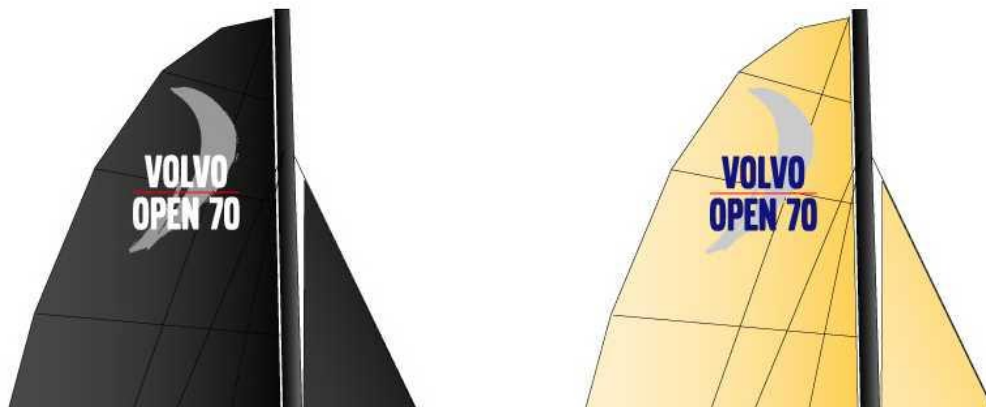

Diagram 3: Examples of use on different sailcloths

## **Appendix B**

### **Declaration Forms**

Designer's Declaration

Spar Manufacturer's Declaration

Builder's Declaration – Yacht

Builder's Declaration – Appendage(s)

Keel Canting System Designers / Manufacturer's Declaration

## VOLVO OPEN 70 RULE – VERSION 3



## Designer's declaration of rule compliance

In accordance with Volvo Open 70 Rule v.3 Rule 2.9, I declare that the yacht ..... which has been issued with Volvo 70 Hull Number ..... has been designed in full compliance with the Volvo Open 70 Rule v.3.

I confirm that compliance with the following rules has been established through detailed calculation and such technical data shall be made available to the MG at their request:

- Rule 2.7.4 Sink per 1mm in measurement afloat trim: .....kg
- Rule 5 Structural Requirements
- Rule 4.16 Permitted Materials for Hull, Deck, Internal Structure and Internal Fittings
- Rule 5.5 Appendage Compartment
- Rule 6 Appendages
- Rule 9.1 Damaged Stability
- Rule 9.2 Angle of Vanishing Stability

<b><u>Designer Declaration</u></b>
Full Name
Representing
Signature
Date

<b>OA, MG or RC Representative</b>
Name
Signature
Date

## VOLVO OPEN 70 RULE – VERSION 3



## Spar Manufacturer's declaration of rule compliance

In accordance with Volvo Open 70 Rule v.3 Rule 2.9, I declare that the spar.....  
 for the yacht ..... which has been issued with Volvo 70 Hull Number .....  
 has been built in full compliance with the Volvo Open 70 Rule v.3

I confirm that compliance with the following rules has been established, and technical data sheets on materials and process shall be made available to the MG at their request:

Rule 10.15 Permitted Materials for Mast, Spreaders, Jumper Strut(s), Boom, Bowsprit and associated standing and running rigging fittings

Rule 10.16 Permitted Materials for Rigging and Associated Fittings

<b><u>Spar Builder's Declaration</u></b>
Full Name
Representing
Signature
Date

<b>OA, MG or RC Representative</b>
Name
Signature
Date

## VOLVO OPEN 70 RULE – VERSION 3



### Builder's declaration of rule compliance - Yacht

In accordance with Volvo Open 70 Rule v.3 Rule 2.9, I declare that the yacht .....  
 which has been issued with Volvo 70 Hull Number ..... has been built in full compliance with the Volvo  
 Open 70 Rule v.3

I confirm that compliance with the following rules has been established, and technical data sheets on  
 materials and process shall be made available to the MG at their request:

- Rule 4.15 Permitted Materials for Deck Equipment and Deck Fittings
- Rule 4.16 Permitted Materials for Hull and Deck (including Spray Dodger), Internal Structure and Internal Fittings
- Rule 6.8 Permitted Materials for Ballast Keel canting mechanism and systems

<b><u>Builder Declaration</u></b>
Full Name
Representing
Signature
Date

<b>OA, MG or RC Representative</b>
Name
Signature
Date

## VOLVO OPEN 70 RULE – VERSION 3



### Builder's declaration of rule compliance – Appendage(s)

In accordance with Volvo Open 70 Rule v.3 Rule 2.9, I declare that the appendage(s) .....  
for the yacht .....which has been issued with Volvo 70 Hull Number .....  
has been built in full compliance with the Volvo Open 70 Rule v.3

I confirm that compliance with the following rules (where applicable) has been established, and technical data sheets on materials and process shall be made available to the MG at their request:

- Rule 6.5 Permitted Materials for Rudders and Daggerboards
- Rule 6.6 Permitted Materials for Ballast Keel Fin (excluding canting mechanism and systems)
- Rule 6.7 Permitted Materials for Keel Bulb
- Rule 6.8 Permitted Materials for Ballast Keel canting mechanism and systems

<b><u>Builder Declaration</u></b>
Full Name
Representing
Signature
Date

<b>OA, MG or RC Representative</b>
Name
Signature
Date

# VOLVO OPEN 70 RULE – VERSION 3



## Keel Canting System Designer / Manufacturer declaration of rule compliance

In accordance with Volvo Open 70 Rule v.3 Rule 2.9, I declare that the canting mechanism & systems .....for the yacht .....which has been issued with Volvo 70 Hull Number ..... have been built in full compliance with the Volvo Open 70 Rule v.3  
I confirm that compliance with the following rules has been established:

Rule 6.4 Load case requirements for the keel, canting mechanism and associated structure.

Rule 6.8 Permitted Materials for Ballast Keel canting mechanisms and systems.

The minimum factors of safety for the listed components when subjected to the loads cases stipulated in Rule 6.4 are herewith supplied in the table below. Calculations have been attached to this declaration demonstrating how the factors of safety recorded in this table have been established. Material conformity documents are also included.

Component	Actual yield strength of material used for calculations	6.4 .1 Load Case 1	6.4.2 Load Case 2	6.4.3 Load Case 3
		Minimum F.O.S (YIELD)	Minimum F.O.S (YIELD)	Minimum F.O.S (YIELD)
Trunions				
Piston rods				
Cylinder tubes				
End covers				
Clevises, and connecting pins				
All thread connections associated with these components				

If cant mechanisms other than hydraulic rams are used, equivalent data shall be provided as specifically requested by the Chief Measurer.

<u>Designer Declaration</u>	<u>Manufacturer's Declaration</u>
Full Name	Full Name
Representing	Representing
Signature	Signature
Date	Date

<b>OA, MG or RC Representative</b>	Date
Name	Signature

**Appendix C**

Volvo Open 70 Class Certificate

THE VOLVO OPEN 70 RULE

**Measurement Certificate  
Certificate Number**

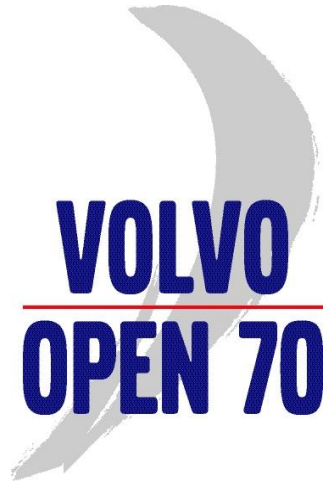

**Yacht's Name**

**National Letters  
And Sail Number**

**Hull Number**

**Designer(s)**

**Builder(s)**

**Owner(s)**

**VALIDATION**

This yacht has been measured by members of the MG in accordance with the Volvo Open 70 Rule v.3 and has been found to be in compliance with the Rule.

Date of certification

Supersedes Certificate No and Date

---

Chief Measurer

---

Class Measurer

# THE VOLVO OPEN 70 RULE



## Measurement Data Certificate Number

### Hull

LOA	
Beam	
Draft	
Weight	
Keel Weight	
Aft Ballast tank volume	

### Rig

MD		CPW	
P		E	
MP		BAD	
J		BSL	
IG		MWT	
IFR		MCG	

### Freeboards

FFM	
MFM	
AFM	

### Measurement Ashore

RPF above DWL	
RPA above DWL	

### Floatation

RPF above MWL	
RPA above MWL	

## VALIDATION

This yacht has been measured by members of the MG in accordance with the Volvo Open 70 Rule v.3 and has been found to be in compliance with the Rule.

Date of measurement

Chief Measurer

Class Measurer

**Appendix D**

**VOLVO OPEN 70 RULE – VERSION 3**

**Application for an exemption from  
Volvo Open 70 Rule – Version 3**



Yacht Name

Volvo 70 Hull Number

-----  
Exemption sought for Version 3 rule number

-----  
Equivalent Volvo Open 70 Rule Version 2 rule number

Intended alternative and reasoning

-----  
Signed

-----  
Date

-----  
Full name

-----  
On behalf of

Official use only	Chief Measurer's Signature	Race Director's Signature	Date:
Application approved			
Application denied			
Additional restrictions and/or controls			
.....			
.....			
.....			
.....			

- Note:
1. Append all supporting documentation to this form.
  2. This application is not approved until the application is marked approved and signed and dated by the Chief Measurer and Race Director.
  3. Exemptions that are granted will not automatically be applied to another yacht. Applications for further exemptions will be considered on a case by case basis.
  4. Exemptions are for the Volvo Ocean Race 2011-2012 only